



Operating Manual for:
Outdoor XUPS-600A/B-1000A/B
MC00032
Issue 3, June, 2013

Table of Contents	Page
1. GENERAL	5
1.1 Product Application.....	5
1.2 Safety Alerts.....	6
1.3 General Cabinet Description.....	6
1.4 Overall Dimensions.....	7
1.5 Construction.....	8
1.6 Doors and Locks.....	8
1.7 Front Access (Electronic/Battery Compartment).....	9
2. MAJOR COMPONENT/CIRCUIT DESCRIPTIONS	9
2.1 XUPS Wiring Diagram.....	9
2.2 Inverter, Charger & Voltage Regulation Transformer.....	10
2.3 Inverter, Charging & Voltage Regulation Circuit Board.....	11
2.4 Filter Board Assembly.....	11
2.5 Input Filter Inductor.....	12
2.6 Alarm Connections.....	13
3. INSTALLATION	13
3.1 Type Installation.....	14
3.2 Required Tools.....	17
3.3 Unpacking & Inspection.....	17
4. POWERING UP THE XUPS	17
4.1 AC Input Connections.....	17
4.2 Energizing the XUPS.....	19
5. MAINTAINING THE XUPS	20
5.1 XUPS Operation.....	20

5.2	Cabinet Integrity	20
5.3	Battery Maintenance.....	20
6.	TROUBLESHOOTING & COMPONENT REPLACEMENT	20
6.1	Troubleshooting.....	20
6.2	Replacing Batteries.....	21
7.	OPTIONAL EQUIPMENT	23
7.1	Optional Battery Heater Circuit Board.....	23
8.	REPAIRS, SERVICE & SPARE PARTS	24
8.1	Repairs.....	24
8.2	Spare Parts.....	24
9.	REFERENCE	25
9.1	Specifications.....	25
9.2	Contact Information.....	27

COPYRIGHT

Copyright © 2013 TSi Power Corporation. All rights reserved.

The information contained in this Document is the property of TSi Power Corporation and contains confidential and proprietary information owned by TSi Power Corporation. Any duplication or disclosure without the written approval of TSi Power Corporation is prohibited.

TRADEMARK

TSi Power, TSi, the TSi Logo and XUPS-600A/B-1000A/B trademarks of TSi Power Corporation.

LIMITED WARRANTY

TSi Power Corporation warrants this product to be free from defects in materials and workmanship for two (2) years from the date of purchase from TSi Power or its authorized representatives. TSi will repair (or at its option, replace) any defective component(s) during this warranty period.

To make a request or claim for service under this limited warranty, the original purchaser must return the product, in the original shipping container or equivalent, to TSi Power or its authorized agent, accompanied by a written receipt showing the date of purchase and both the model name and serial number of the product.

Warranty does not cover transportation costs. Damage by misuse, accident or unauthorized tampering of the product is not covered by the warranty. NO OTHER WARRANTIES ARE EXPRESSED OR IMPLIED. TSI IS NOT LIABLE FOR CONSEQUENTIAL DAMAGES. THIS WARRANTY GIVES YOU SPECIFIC LEGAL RIGHTS, AND YOU MAY ALSO HAVE OTHER RIGHTS WHICH VARY FROM STATE TO STATE.

LIMITATION OF LIABILITY

IN NO EVENT SHALL TSi POWER CORPORATION BE LIABLE FOR ANY DAMAGES WHATSOEVER (INCLUDING WITHOUT LIMITATION, DAMAGES FOR LOSS OF BUSINESS PROFITS, BUSINESS INTERRUPTION, LOSS OF BUSINESS INFORMATION, OR OTHER PECUNIARY LOSS) ARISING OUT OF THE USE OR INABILITY TO USE THIS PRODUCT, EVEN IF TSI POWER OR ITS AGENT HAVE BEEN ADVISED OF THE POSSIBILITY OF SUCH DAMAGES. SOME STATES DO NOT ALLOW THE LIMITATION OR EXCLUSION OF LIABILITY FOR INCIDENTAL OR CONSEQUENTIAL DAMAGES, SO THE ABOVE EXCLUSIONS MAY NOT APPLY TO YOU.

REVISIONS

<u>ISSUE</u>	<u>DATE</u>	<u>REASON FOR REVISION</u>
1	July, 2011	Initial Issue
2	September, 2012	Reissued for new P/N & updates
3	June, 2013	Reissued to incorporate new main Circuit Board

1. GENERAL

1.1 PRODUCT APPLICATION

This outdoor UPS is ideal for the protection of telecom DAS systems/sewage control systems/perimeter surveillance and security/gate control systems, LED traffic light/roadway display systems and industrial remote terminal units (RTUs). It is equipped with wide-temperature, pure lead, gel batteries and is housed in a weather-protected enclosure. It offers line-interactive automatic voltage regulation, over/under voltage protection, surge protection with heavy duty noise filtering, communications capability and optional extended battery backup.



Figure 1: The XUPS-600A/B and 1000A/B Cabinet

1.2 SAFETY ALERTS

SAFETY SIGNAL WORD DEFINITIONS

This document contains safety alert pictorial Symbols and Words that point out areas and procedures that require special attention with regards to safety. These Symbols and Words are defined in ANSI Z535.4-1998, Product Safety Signs and Labels.



DANGER:

DANGER indicates an imminently hazardous situation which, if not avoided, will result in death or serious injury.



WARNING:

WARNING indicates a potentially hazardous situation which, if not avoided, will result in death or serious injury.



CAUTION:

CAUTION indicates an imminently hazardous situation which, if not avoided, may result in minor or moderate injury. It may also be used to alert against unsafe practices.

The safety alert pictorial symbol  appears in this document to make users aware of important operating and safety concerns.

1.3 GENERAL CABINET DESCRIPTION

- Built-in automatic voltage regulation enables a wide-input voltage window to deliver power while preventing unnecessary battery drain.
- LED status indicators show voltage, load and battery levels.
- The XUPS is compatible with high-quality generators.
- The cabinet can be pole mounted.
- Rain tested to UL 50E standards.
- Heavy-duty surge protection and noise filtering protects load and UPS.
- The XUPS uses wide-temperature, pure lead, gel batteries and internal cooling fan to extend battery life and protect electronic components.
- Operates in line mode with bad battery bank, which prevents unscheduled service calls.

- The XUPS is easier to repair because internal circuit board assemblies are connectorized.
- Precise output current limiting permits start of induction motors and other difficult loads.
- Includes a two-year limited warranty.

1.4 OVERALL DIMENSIONS – The Outdoor XUPS-600A/B-1000A/B cabinet is 24" (610 mm) H x 24" (610 mm) W x 13.7" (348 mm) D and weighs 160 lbs / 72 kg (with 4 batteries), see Figure 2.



Figure 2: Outdoor XUPS-600A/B-1000A/B Dimensions

- 1.5 CONSTRUCTION** – The Outdoor XUPS-600A/B-1000A/B cabinet is constructed of 5052-H32 aluminum and finished with a gray polyester powder coat that is designed to meet Telcordia specifications for protection against corrosion, water intrusion beyond NEMA 3R, UV radiation and impact resistance. The Outdoor XUPS-600A/B outputs 420 W at 4.4 A while the Outdoor XUPS-1000A/B outputs 700 W at 7.3 A.
- 1.6 DOORS & LOCKS** – The electronic/battery compartment is accessed by a front door which is retained by stainless steel hinges and secured by a slotted screwdriver actuated quarter–turn lock. This lock provides for proper compression gasket sealing and prevents unauthorized entry.

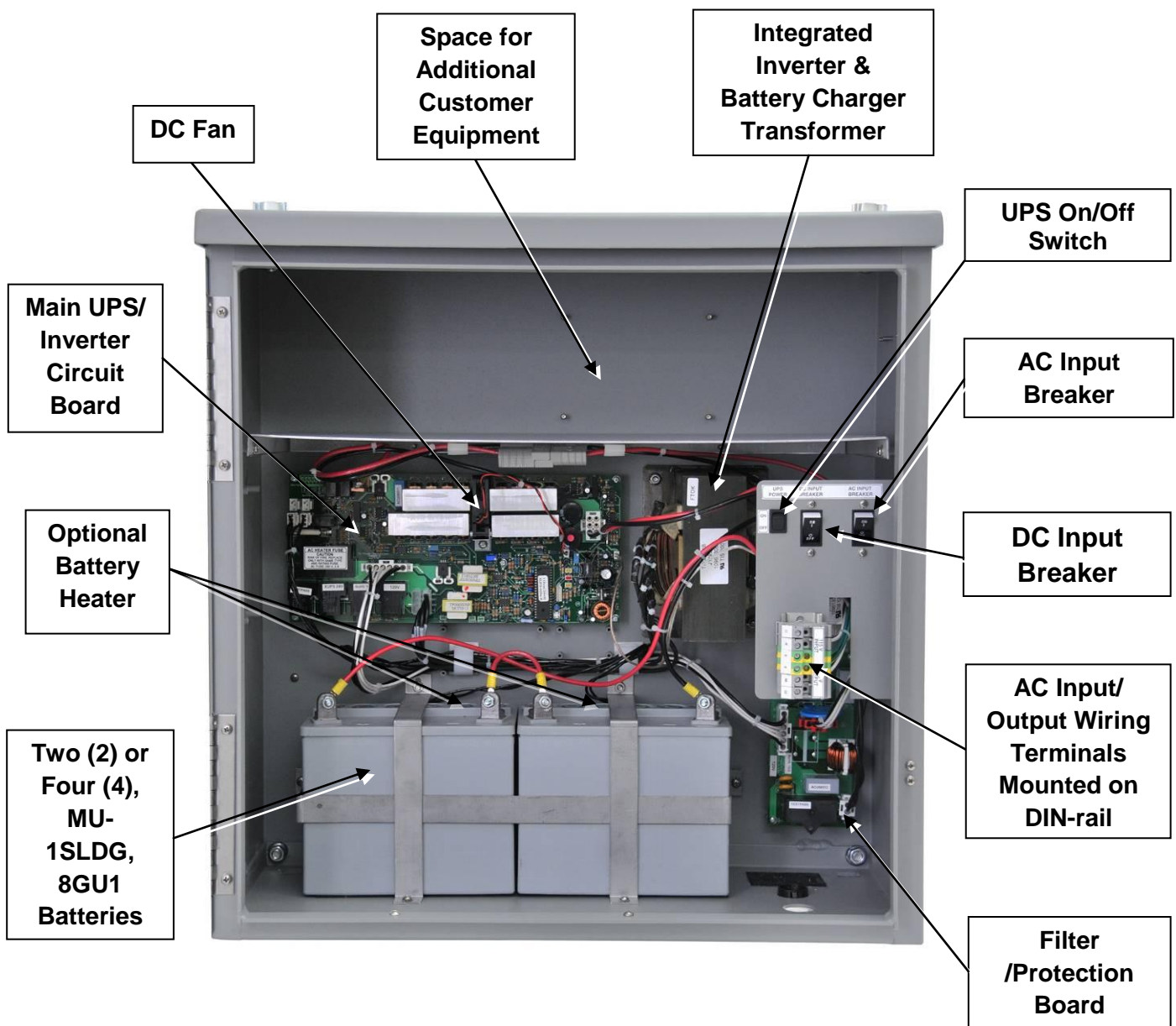

Figure 3: Electronic/Battery Compartment w/Door Open

1.7 FRONT ACCESS (Electronic/Battery Compartment) See Figure 3

With the front door open, both the electronics and batteries are readily accessible for ease of testing, servicing or component replacement.

2. MAJOR COMPONENT/CIRCUIT DESCRIPTIONS

2.1 XUPS WIRING DIAGRAM –

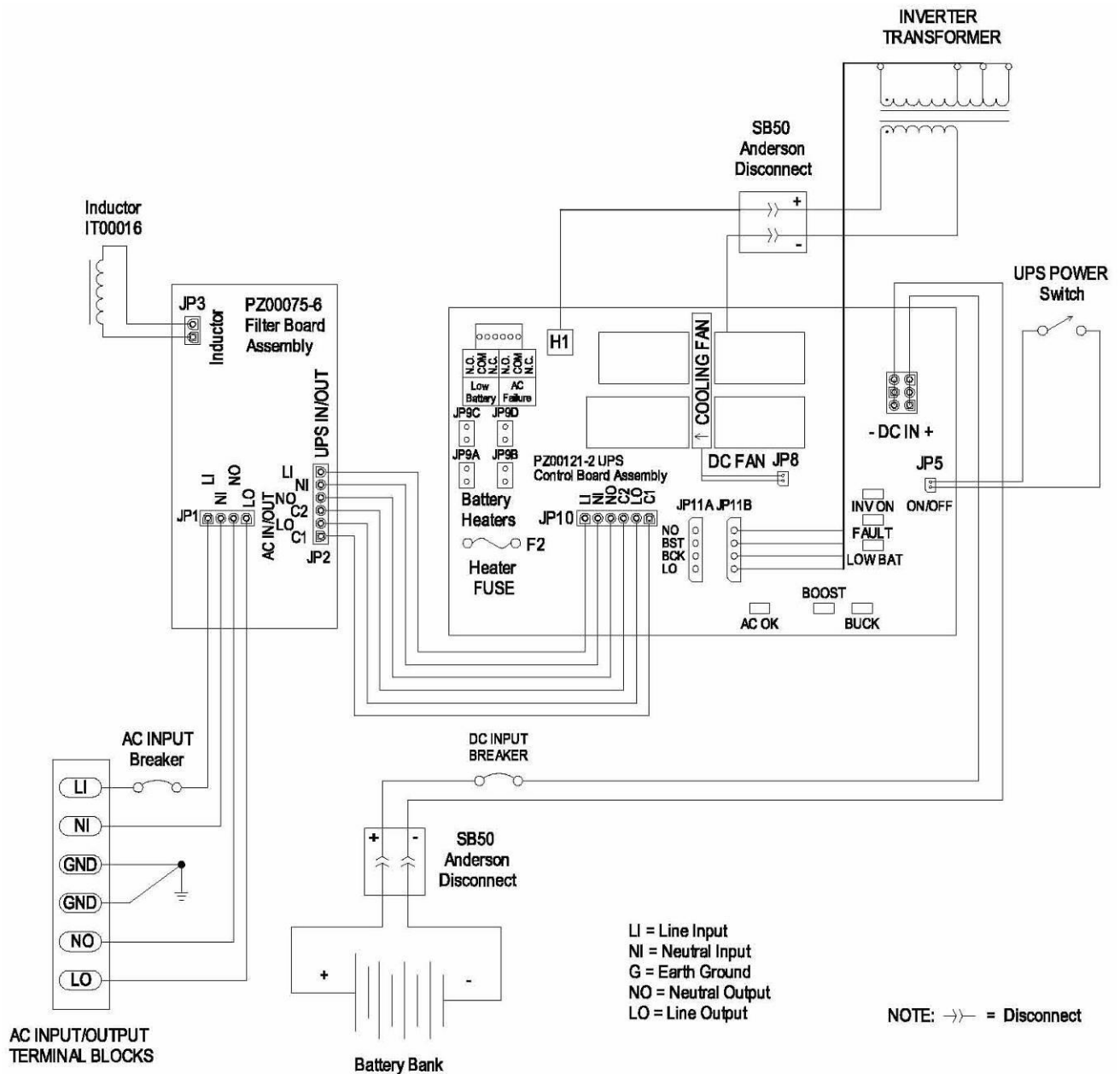

Figure 4: Outdoor XUPS-600A/B-1000A/B Wiring Diagram

2.2 INVERTER, CHARGER & VOLTAGE REGULATION TRANSFORMER

The main transformer of the Outdoor XUPS is connected to the main circuit board and performs three functions: (see Figure 5):

1. Inverter transformer
2. It acts as an auto transformer adjusting the mains voltage as required
3. It charges the Battery Bank as required



Figure 5: Inverter & Voltage Regulation Transformer

2.3 INVERTER, CHARGING & VOLTAGE REGULATION MAIN CIRCUIT BOARD

The control board of the Outdoor XUPS uses a rugged design with a microprocessor-controlled 20 kHz sinewave inverter (see Figure 6). The circuit boards are conformally coated for use in severe outdoor environments. The control board includes integral LED indicators for AC OK, BOOST and BUCK as well as INV ON, FAULT and LOW BAT to provide a real-time status of the XUPS' operation.

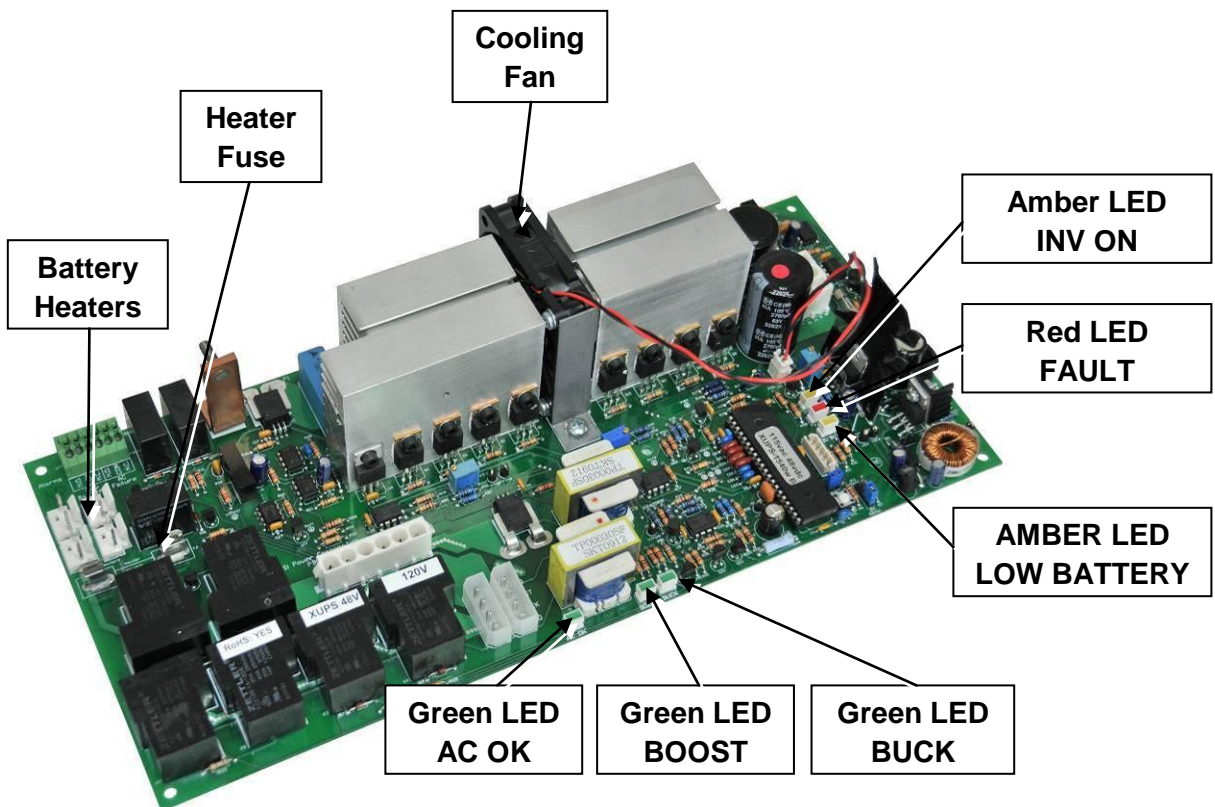

Figure 6: Main Inverter, Charging & Voltage Regulation Circuit Board

2.4 FILTER BOARD ASSEMBLY

The Outdoor XUPS-600A/B-1000A/B is protected against surge voltages by a proprietary circuit board. This board uses a 40mm MOV to provide protection and assure the continued function of the XUPS (see Figure 7).

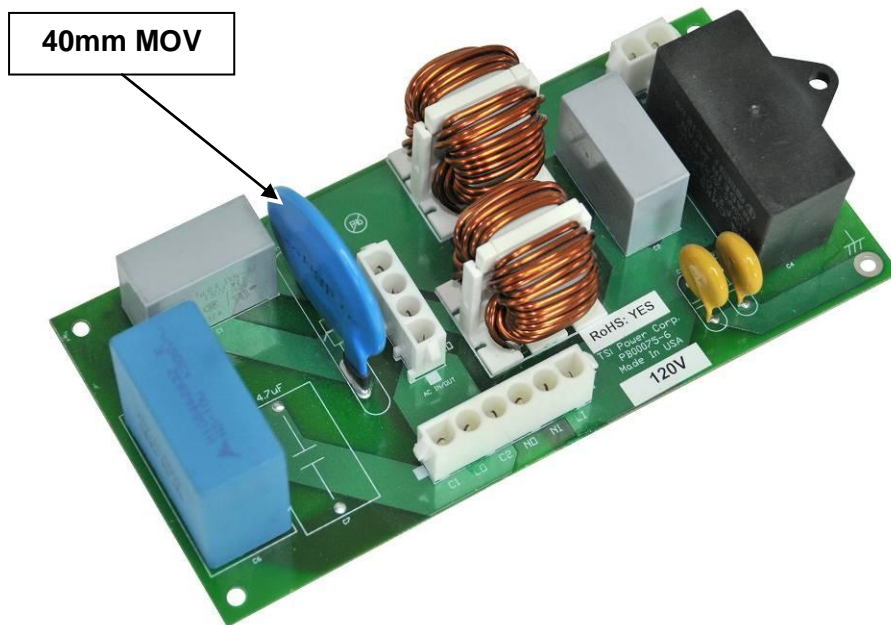

Figure 7: Filter Board Assembly

2.5 INPUT FILTER INDUCTOR

This 1mh, iron core filter inductor is off board and is placed after the surge protection circuit. It filters out normal mode noise between the line and neutral branches of the incoming AC (see Figure 8).



Figure 8: AC Input Filter Inductor

2.6 ALARM CONNECTIONS

Alarm connection terminations which have been integrated into the main control board and are located in the upper left corner of the board. To connect the alarm wires, insert the stripped wire into the desired Wire Inlet and press the corresponding Compression Tab on the connector (see Figure 9).

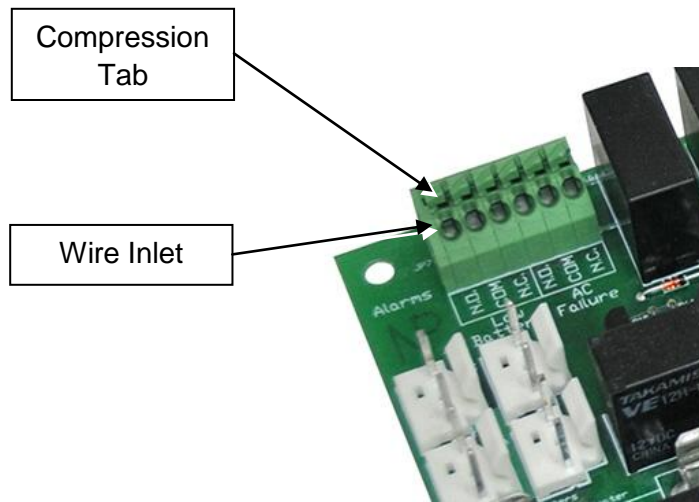

Figure 9: Alarm Connections

2.61 Low Battery Alarms

N.O. – COM: Open = Battery OK

N.C. – COM: Closed = Battery OK

2.62 AC Failure Alarms

N.O. – COM: Open = AC OK

N.C. – COM: Closed = AC OK

3. INSTALLATION

IMPORTANT: ONLY QUALIFIED PERSONNEL SHOULD PERFORM THE INSTALLATION OF THIS PRODUCT.



CAUTION: Make sure that appropriate lifting equipment is used and that company safety practices are followed.

3.1 TYPE – The Outdoor-XUPS-600A/B-1000A/B Series can be installed in any one of three configurations:

3.11 Wall - Mount

- In this configuration, the unit can be mounted vertically to a solid wall by means of four (4) mounting feet that are provided and attached as standard items when the XUPS is ordered (see Figure 10).
- Before this unit is mounted, it is important to determine the load bearing capabilities of the mounting surface and to make sure that company practices regarding safety are followed.

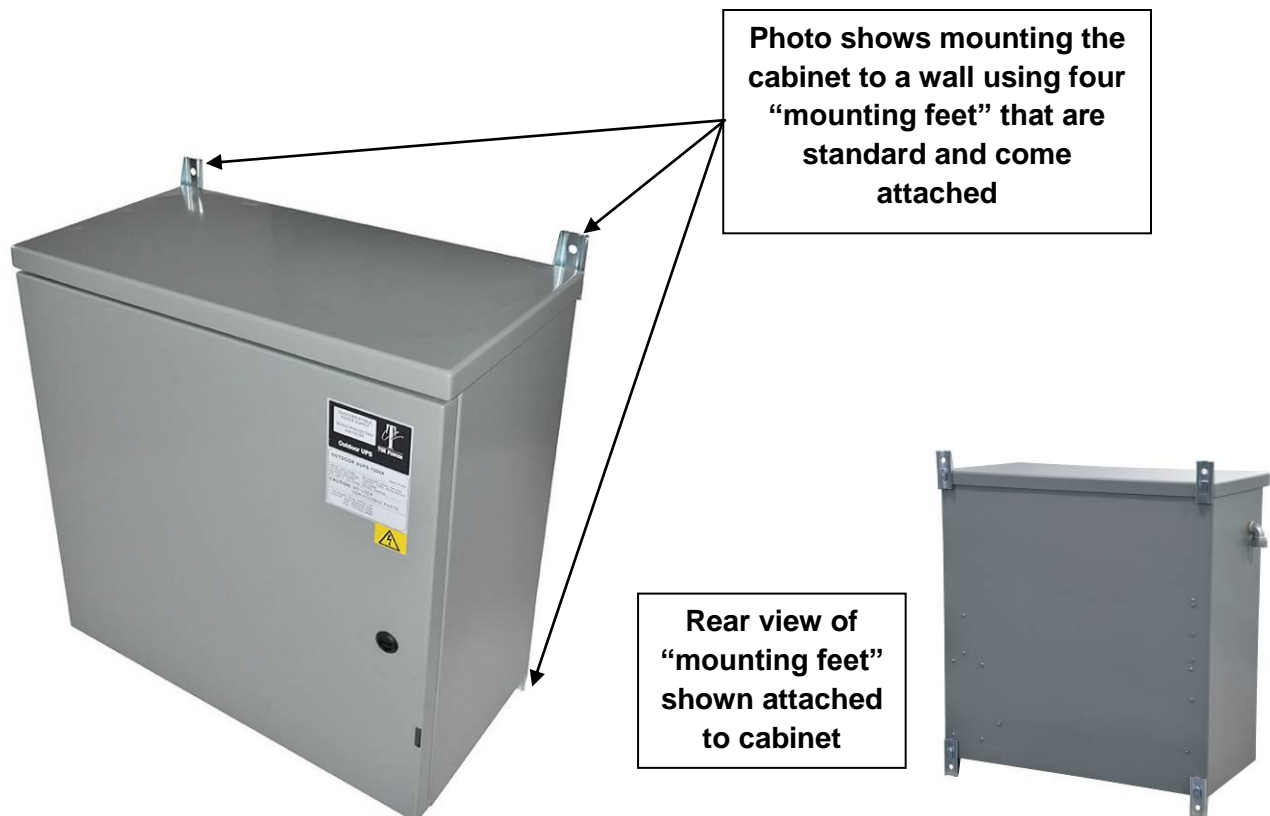

Figure 10: Wall Mounting of Outdoor XUPS

3.12 Pole - Mount

- When ordering the Outdoor XUPS for this application, an optional pole-mount bracket must be included.

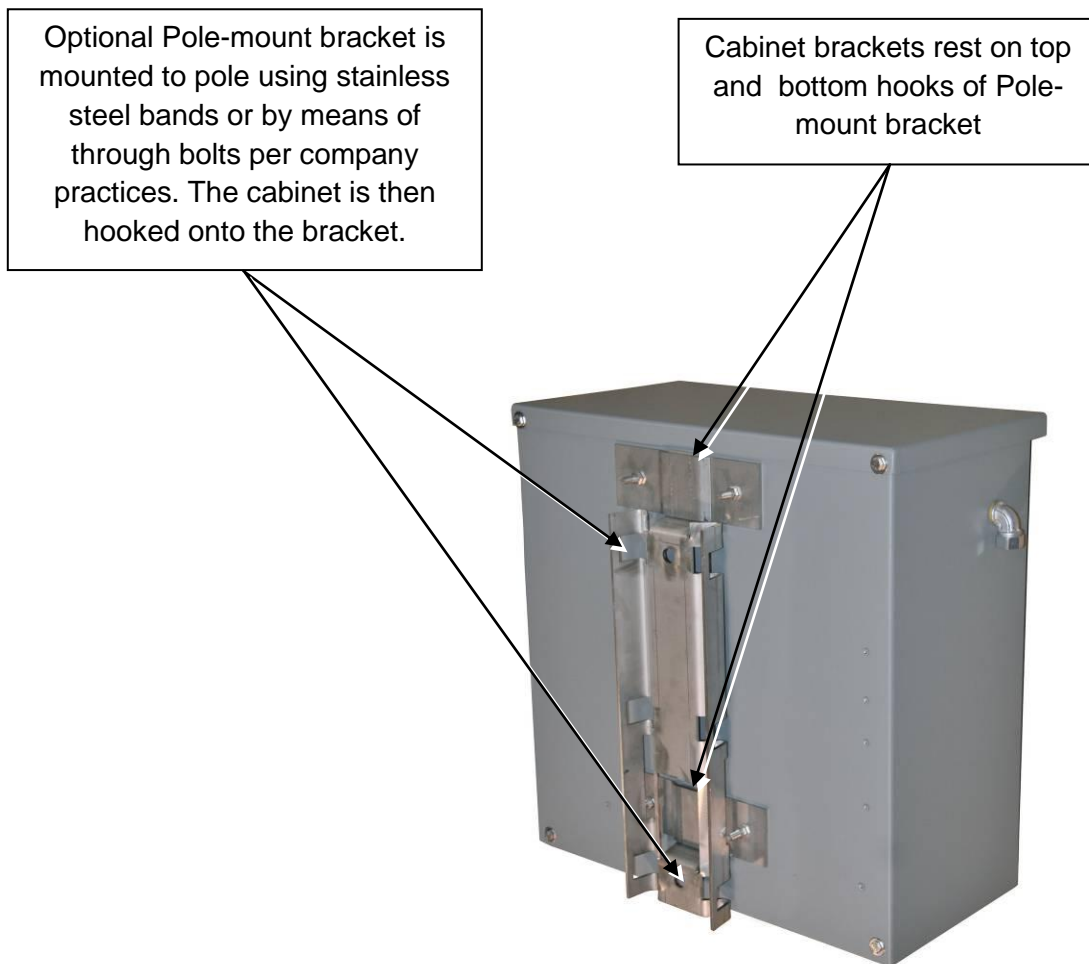

Figure 11: Mounting of Outdoor XUPS to a Pole

- This product is intended for installation in RESTRICTED ACCESS LOCATIONS ONLY.
- It is recommended that this unit be installed as a Walk-Up unit making sure that the center of the door is at an eye-level height for optimum accessibility and ease of installation.
- The cabinet should be mounted on the power pole in such a manner so that the door doesn't open onto a road or a driveway.
- Position the cabinet on the pole so that the cabinet rests where the cable can easily enter the cabinet from the bottom. If bringing in cable through a conduit up the pole, make sure that the trade size of the conduit is no larger than $\frac{3}{4}$ ". Larger conduit will not fit through the cable fitting.

- Make sure that the door clearances around the unit provide for unobstructed access.
- Fasten the pole-mount bracket to the pole by means of through bolts or stainless steel banding of size and type to be determined by local practices (see Figure 11).
- Slide the unit onto the pole-mount bracket as shown in Figure 11.
- Provide a 15 A, 120 V service with a disconnect switch in the near vicinity of the XUPS.

3.13 Pad-Mount

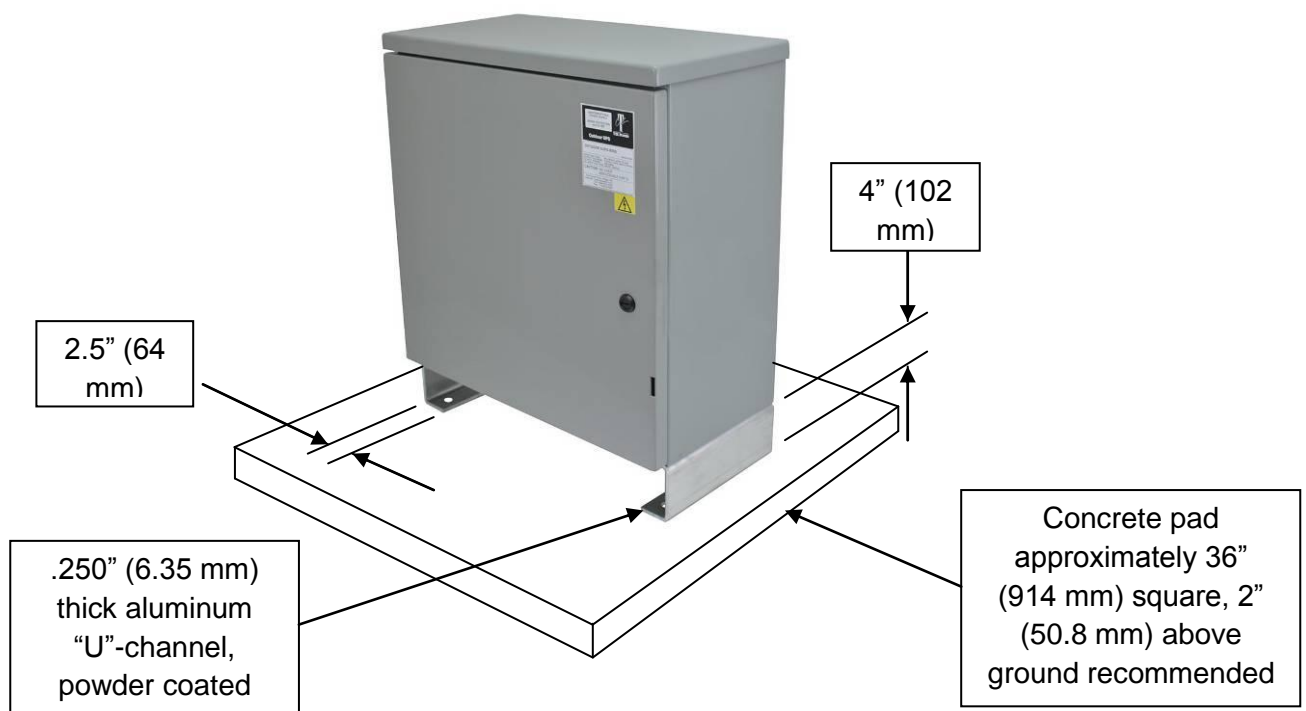

Figure 12: Pad-Mounting the Outdoor XUPS

- When the XUPS is to be mounted on a pad, two optional U-channels must also be ordered. They will be attached to the cabinet when shipped.
- Prepare ground surface and pour concrete pad per local company practices and to approximate size as shown in Figure 12. If composite pad is used, follow manufacturer's instructions.
- Use the four (4) pre-punched holes in the U-channels to position and mount the cabinet assembly to the pad per local practices.

3.2 REQUIRED TOOLS

- A standard slotted screwdriver to open the front door
- A standard telco socket wrench set and standard mechanic telco tools
- Appropriate lifting equipment to lift and secure the unit to the appropriate mounting location. The weight with four batteries is 160 lbs (72 kg)

3.3 UNPACKING & INSPECTION

3.31 The units are shipped in wooden crates, each containing one to three units. The units are placed on a pallet with protective material between them.

3.32 Carefully open the crates, making sure not to damage the units, and remove the protective wrap and packing material.

3.33 Before the units are removed from the crates, inspect them for physical damage.

3.34 If no damage is found, remove the units from the crates, open the door and again inspect for damage. If damage is found in steps 3.32, 3.33 or 3.34, do not accept the shipment and file a claim with the carrier. Contact TSi Power for assistance if necessary.



CAUTION: The units may contain charged batteries capable of causing fire and injury if shorted across terminals. Be very careful not to short terminals accidentally when unpacking.

4. POWERING UP THE Outdoor XUPS

Before powering up the unit, make sure that the air inlet and exhaust ports are free of obstruction to prevent overheating.

4.1 AC INPUT CONNECTIONS

4.11 Make sure that an AC, 15 A, 120 V service with a disconnect switch is provided near the XUPS and confirm that it is switched **OFF**.

4.12 If bringing in cable through a conduit up the pole, make sure that the trade size of the conduit is $\frac{3}{4}$ " and not larger. Larger conduit will not fit through the $\frac{3}{4}$ " conduit holes for cable entry which are on the bottom of the unit, see Figure 13. The cool air intake vent is also located on the bottom.

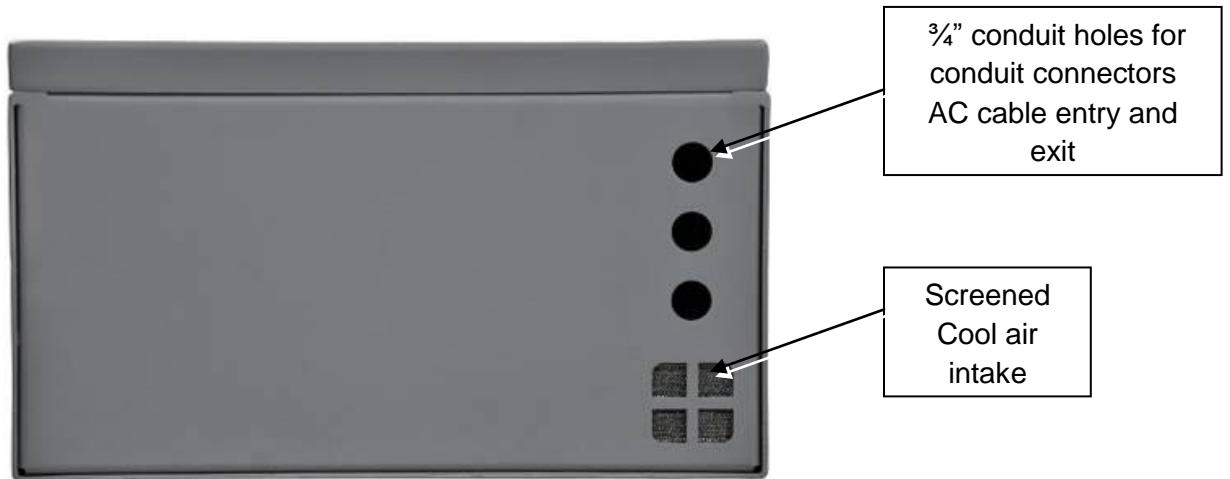

Figure 13: Cable Entry and Exit Ports in Bottom of Cabinet

- 4.13** Use 12 AWG wire with a 105° C insulation system for all conductors.
- 4.14** Allow for sufficient wire length to reach the wiring terminals and leave enough slack to reduce the stress in the wires.
- 4.15** Strip approximately 3/8" (9.52 mm) insulation from the end of each of the six (6) incoming / outgoing AC wires and terminate them in the wiring terminals located on the right side of the cabinet (see Figure 14).
- 4.16** Terminate the incoming wires on the terminals marked as shown in Figure 14 and as follows:
- **LI** is for phase conductor (black)
 - **NI** is for neutral conductor (white)
 - **G** is for safety ground
- 4.17** Terminate the outgoing wires on the terminals marked as shown in Figure 14 and as follows:
- **LO** is for phase conductor (black)
 - **NO** is for neutral conductor (white)
 - **G** is for safety ground

4.18 In terminating the wires as outlined in 4.16 & 4.17 above, use a slotted screwdriver to tighten the terminal screws until the wires are secure. Do not apply excessive torque to make sure that the terminal screws are not damaged. Once the screws have been tightened, gently tug on the wires to make sure that they are properly connected.

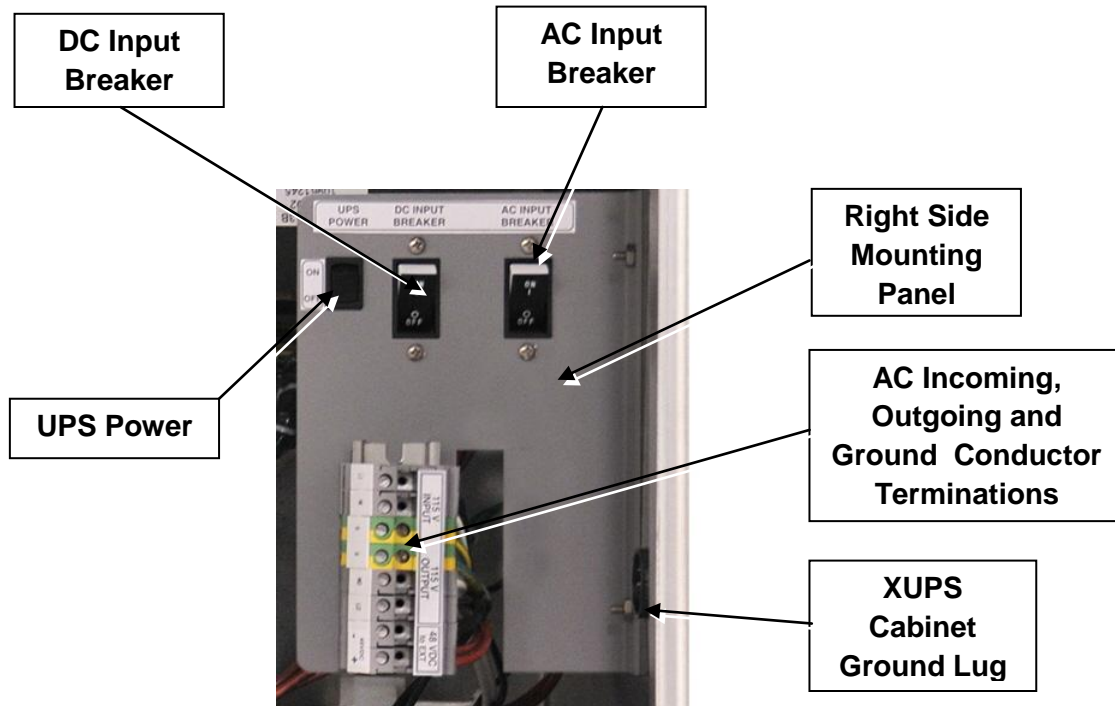

Figure 14: Incoming & Outgoing Wire Terminations



WARNING: TO PREVENT DAMAGE MAKE SURE TO CHECK THAT THE INPUT & OUTPUT WIRES ARE NOT REVERSED

4.2 ENERGIZING THE XUPS

The following steps outline the procedures for putting the XUPS into operation:

- 4.21** Turn on the AC, 15 A, 120 V service by putting the **AC INPUT BREAKER** to the **ON** position (see Figure 14).
- 4.22** Turn **on** the **DC INPUT BREAKER**.
- 4.23** Turn **on** the **UPS POWER SWITCH**.
- 4.24** Verify that all LEDs on the Control Board Assembly (see Figure 6) illuminate one by one. **THIS MAY TAKE APPROXIMATELY FIVE (5) SECONDS.**

4.25 Verify that the following LEDs are illuminated:

1. Verify that the **AC OK** is illuminated.
2. If LED **INV ON** remains on or fluctuates between **AC OK** and **INV ON**, check with power company for out of mains voltage tolerance.
3. Once the green LED **AC OK** stabilizes and remains ON: **THE SYSTEM IS NOW READY FOR OPERATION.**

5 MAINTAINING THE OUTDOOR XUPS-600A/B-1000A/B

To make sure that the unit is functioning properly and safely, check the following periodically or at least once a year:

5.1 Outdoor XUPS OPERATION

5.11 Switch-off AC Breaker disconnect.

5.12 Verify that the XUPS operates in **Inverter Mode** with **Amber LED ON**.

5.2 CABINET INTEGRITY

5.21 Check the air intake and exhaust for dust and debris. Remove as required.

5.22 Check for moisture and water accumulation and remove as necessary.

5.23 Check to make sure locks are functioning properly and have not been vandalized. Replace if necessary.

5.24 Check the gaskets to make sure that door seals are still tight and effective. Replace if necessary.

5.3 BATTERY MAINTENANCE

See Section 6 for battery replacement.

5.31 Check the batteries for electrolyte leakage. Clean up and replace if necessary.

5.32 Disconnect battery cable from battery to be checked. Measure the battery terminal voltage of all batteries. Each battery should have a terminal voltage of 13.5 VDC $\pm 0.3V$. Replace **All** batteries if the difference is larger than $\pm 0.3V$.

6 TROUBLESHOOTING & COMPONENT REPLACEMENT

6.1 TROUBLESHOOTING

The Outdoor XUPS-600A/B-1000A/B is designed to facilitate quick replacement of circuit boards in the field. Therefore, troubleshooting procedures described in this manual are limited to visual inspection and board and battery replacement only. More detailed troubleshooting, repair and calibration can only be done at the TSi Power factory.

6.2 REPLACING BATTERIES



DANGER: The servicing or replacement of batteries should be restricted to qualified and experienced personnel.

- Use extreme care when handling the batteries.
- When lifting the batteries wear heavy gloves and safety glasses at all times.
- Do not wear rings, metal wrist bands, or bracelets.
- Do not allow metal objects to come in contact with the terminal side of the batteries.
- Use tools with insulated handles.
- Disconnect charging source prior to connecting or disconnecting battery terminals.
- Determine if battery is inadvertently grounded. If inadvertently grounded, remove source from ground. Contact with any part of a grounded battery can result in electric shock. The likelihood of such shock can be reduced if such grounds are removed during installation and maintenance.



CAUTION: Do not dispose of batteries in a fire. The batteries may explode.



CAUTION: Do not open or mutilate batteries. Released electrolyte is harmful to the skin and eyes. It may be toxic.



CAUTION: A battery can present a risk of electric shock and high short-circuit current.

AVERTISSEMENT: Ne jetez pas les batteries dans un feu. Elles pourraient exploser.

AVERTISSEMENT: N'ouvrez pas et n'altérez pas physiquement les batteries. La solution électrolyte qui sera libérée est dangereuse pour la peau et des yeux. Elle pourrait même être toxique.

ATTENTION: Une batterie peut présenter un risque de décharge électrique et un fort courant de court-circuit.

6.21 The battery compartment(s) holds two (2) or four (4) 31Ah, 8GU1, MK Batteries. See Figure 17.

6.22 Only 8GU1-MU-1SLDG (without handle) sealed, valve-regulated gel batteries made by MK Battery should be used. The TSi part number for the battery is VB00010.

6.23 The following battery replacement procedure should be followed:

- Turn off AC circuit breaker,
- Turn off external disconnect,
- Turn off DC circuit breaker,

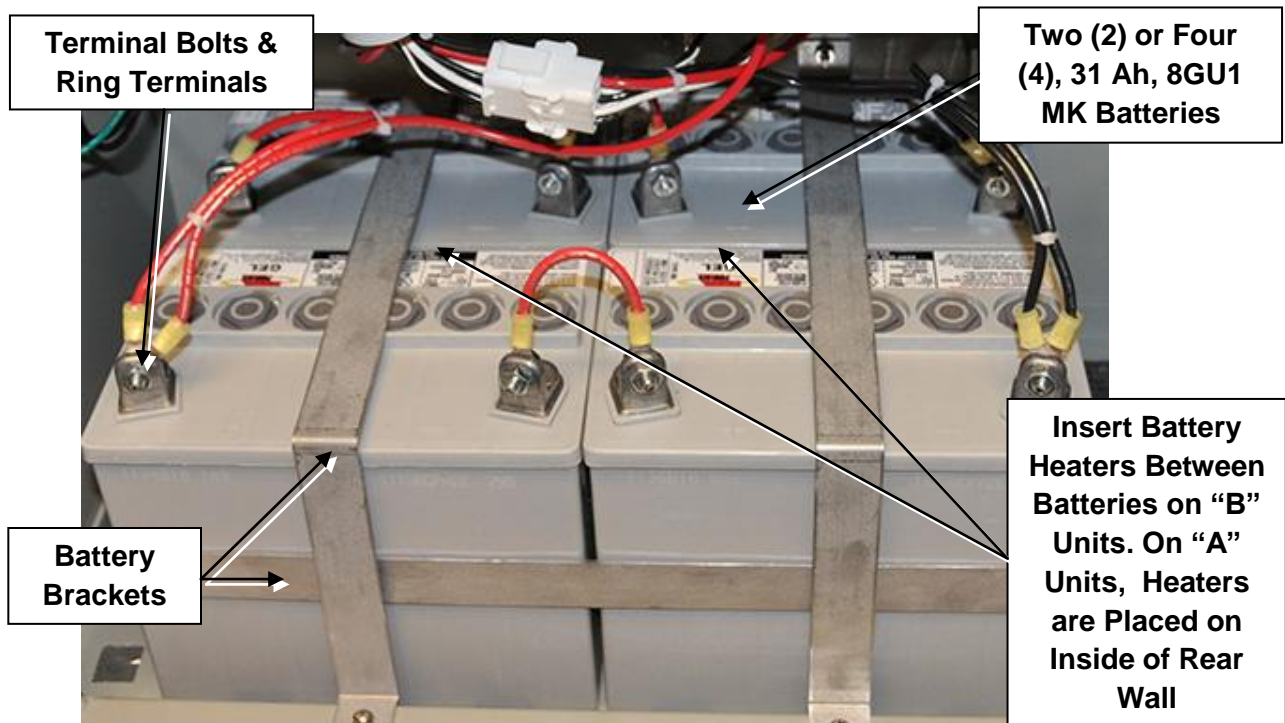

Figure 17: Four (4) Battery B-Configuration Shown in Open Battery Compartment

- Loosen terminal bolts,
- Remove ring terminal connections one by one and save hardware,
- Set battery jumpers aside,
- Remove battery brackets (if equipped).
- Pull out old batteries carefully, set them aside,
- If heating pads are used, set them aside,

- Install new batteries. If heating pads are used, follow the instructions shown in section 7.
- Reinstall battery brackets,
- Connect battery jumpers and cables using the hardware that came with the new batteries. Tighten bolts and nuts lightly.
- Torque bolts in accordance with battery manufacturer's specifications.
- Check all connections,
- Re-energize system,
- Dispose of old batteries in accordance with battery manufacturer's instructions.

7. OPTIONAL EQUIPMENT

7.1 OPTIONAL BATTERY HEATER CIRCUIT BOARD

The optional battery heating pads are constructed from printed circuit boards with resistor networks that are encapsulated in epoxy. The AC current flows through the resistors to generate heat. By being pressed against the walls of the batteries, the batteries are heated.

Installation of the heater pads is as follows:

- Turn the AC circuit breaker off,
- Turn the DC circuit breaker off,
- Remove connections between batteries (save hardware),

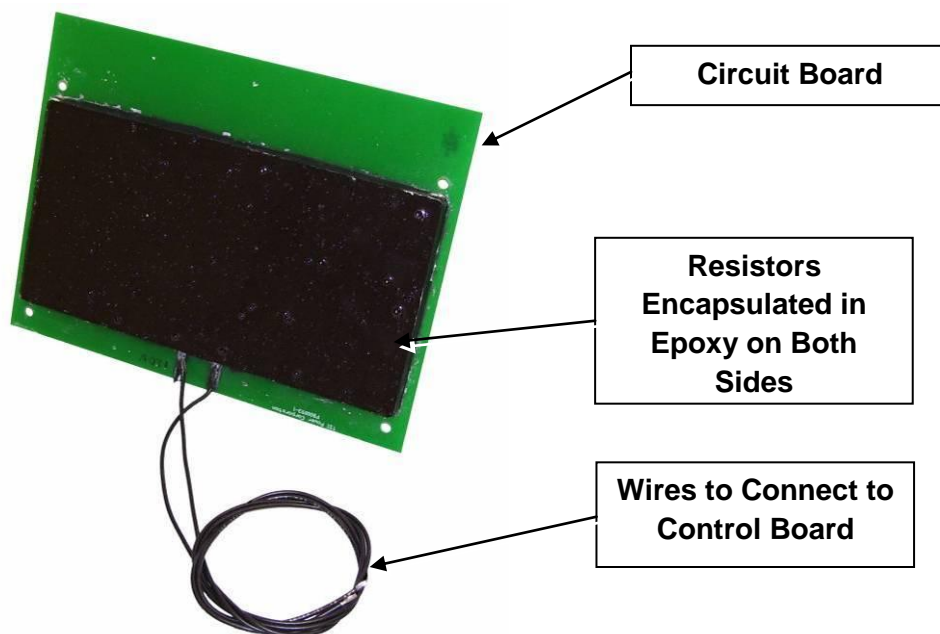

Figure 18: Optional Battery Heater Circuit Board

- Remove battery brackets,
- Remove batteries by pulling them out of compartment,
- Remove "bump-ons" from either side of compartment,
- Place heating pads against inside rear wall of cabinet for "A" units and insert heating pads between batteries, for "B" units,
- Push batteries back in,
- The heating pad should now be secure between the batteries or batteries and rear wall,
- Replace battery brackets,
- Run the wires back to the control PCB and mate connector with header.
- Restart the XUPs

8. REPAIRS, SERVICE & SPARE PARTS

8.1 REPAIRS - The Outdoor XUPS-600A/B-1000A/B should only be repaired by persons with knowledge of power electronics and electrical safety procedures. Others should contact TSi Power Corporation for a Return Material Authorization (RMA). The TSi service representative will determine if factory repair is necessary and issue an RMA. A replacement unit will be shipped to certain customers with service agreements. TSi retains the repaired unit.

8.2 SPARE PARTS - The table below contains information on replaceable parts that can be ordered from TSi if necessary.

Description	TSi Part Number	Manufacturer	Mfg. Part No.
Main UPS PCB	PZ00121-2	TSi Power	N/A
Filter/Surge Protection PCB	PZ00075-6	TSi Power	N/A
Input inductor	IT00016	Johnson Electric Coil	J13939
Inverter transformer	TP00194	Johnson Electric Coil	J14394 (RoHS Compliant)
Battery breaker 600/1000	FC00081/FC00082	Airpax	IELBX1-1-72-30.0-M3-V/ IELBX1-1-72-40.0-M3-V
AC Input breaker	FC00016	Carling Technologies	A11-B0-34-610-111-C

31 Ah battery	VB00010	MK Battery	8GU1
---------------	---------	------------	------

9. REFERENCE

9.1 SPECIFICATIONS

Input	
Voltage Range	96 to 136 VAC
Voltage Regulation	115 VAC \pm 8%
Frequency	47 - 63 Hz \pm 5%
Current (600/1000) max charging @ low line	7 A / 10 A
Circuit Breaker (600/1000)	10 A / 10 A
Output	
Output Power (600/1000)	420 W / 700 W
Power Factor (True non-displacement)	0.7
Current (600/1000) @ low line	4.4 A / 7.3 A
Waveform & Harmonic Distortion	Sine wave, <3% THD with linear load
Power Efficiency in AC Line Mode	Line: 97%
Power Efficiency in Inverter Mode	Inverter: 92% under full load conditions
Transfer Time AC Line to Inverter	0 to 8 ms
Battery	
Type	Two or four, wide temperature, sealed 12 VDC gel, valve-regulated, lead-acid, maintenance free (sold separately)
Temperature Range Fully Charged	-4° to +140° F (-20° C to +60° C), -40° to +140° F (-40° C to +60° C) with optional battery heater
Capacity Ah @ 20 hr rate and bus	31 Ah or 62 Ah / 31 Ah or 62 Ah

voltage (600A or B / 1000A or B)	
Number of batteries (600A or B / 1000A or B)	2 or 4 / 2 or 4
Circuit Breaker (600/1000)	30 A / 40 A magnetic type
Weight per battery (lb/kg)	23 / 10.5
Dimensions (in/mm)	7.71L x 5.18W x 7.22H/196L x 132W x 183H
Runtime (600A or B / 1000A or B)	45 min / 2 hr 4 min @ 420 W, 22 min / 57 min @ 700 W
Recharge Time (600A or B / 1000A or B)	A = 6 hr / B = 12 hr to 90%
Battery Heater Pad	34 W
LED Indicators	
INVERTER ON	Amber, Solid
FAULT ON	Red, Solid or flashing
LOW BATT ON	Amber, Solid
BUCK ON	Green, Solid
BOOST ON	Green, Solid
AC OK ON	Green, Solid
Mechanical	
Dimensions (in/mm)	24W x 13.7D x 24H / 610W x 348D x 610H
Weight, without batteries (lb/kg)	60 / 27.22
Weight, with batteries, 600A/1000A (lb/kg)	110 / 45.36
Weight, with batteries, 600B/1000B (lb/kg)	160 / 72.58
Environmental	
Operating Temperature* (with heater)	-40° F to +122° F (-40° C to + 50° C)
Operating Temperature** (without heater)	14° to +122° F (-10° C to + 50° C)

Storage Temperature	-76° F to 140° F (-60° C to 60° C)
Humidity	0 to 95 % non-condensing
* Duration of storage will determine the need for supplemental charge, especially at elevated temperatures. ** Extended exposure to temperatures >40° C may shorten battery life.	
Mounting Configuration	
Wall-Mount (comes equipped w/4 mounting feet; Pole-Mount (comes equipped w/optional Pole-Mount Bracket – PM-1); Pad-Mount (comes equipped w/optional Pad-Mount U-Channels)	
Agency Compliance	
Rain tested to UL 50E and designed to UL 60950-1 and UL 1778	

9.2 TSi POWER CONTACT INFORMATION

TSi Power Corporation
1103 West Pierce Avenue
Antigo, WI 54409, USA
Toll-Free Tel: 800-874-3160 (for USA & Canada only)
Tel: +1-715-623-0636
Fax:+1-715-623-2426
URL: www.tsipower.com E-mail: sales@tsipower.com