



TSi Power Corporation

Operating Manual for: Outdoor XUPs-1500-7070

Issue 2, February, 2012

Table of Contents	Page
1. GENERAL	5
1.1 Product Application.....	5
1.2 Safety Alerts.....	6
1.3 General Cabinet Description.....	6
1.4 Overall Dimensions.....	7
1.5 Construction.....	7
1.6 Doors and Locks.....	7
1.7 Left Side Access	8
1.8 Right Side Access	9
2. MAJOR COMPONENT/CIRCUIT DESCRIPTIONS	10
2.1 XUPS Wiring Diagram.....	10
2.2 Inverter, Charger & Voltage Regulation Transformer.....	10
2.3 Inverter, Charging & Voltage Regulation Circuit Board.....	11
2.4 Display Circuit Board.....	12
2.5 Alarm Circuit Board.....	12
2.6 AC Surge Protection Circuit Board.....	13
2.7 Input Filter Inductor.....	14
3. INSTALLATION	14
3.1 Site Selection & Preparation.....	14
3.2 Required Tools.....	15
3.3 Unpacking & Inspection.....	15
3.4 Installing the XUPS.....	15
4. POWERING UP THE XUPS	16
4.1 AC Input Connections.....	17
4.2 Energizing the XUPS.....	18

5. MAINTAINING THE XUPS	19
5.1 XUPS Operation.....	19
5.2 Cabinet Integrity	19
5.3 Battery Maintenance.....	20
6. TROUBLESHOOTING & COMPONENT REPLACEMENT	20
6.1 Status Alarms.....	20
6.2 Replacing Batteries.....	20
7. OPTIONAL EQUIPMENT	23
7.1 BH5 Battery Heater	23
8. REPAIRS, SERVICE & SPARE PARTS	24
8.1 Repairs.....	24
8.2 Spare Parts.....	24
9. REFERENCE	25
9.1 Specifications.....	25
9.2 Product Configuration.....	27
9.3 Contact Information.....	27

COPYRIGHT

Copyright © 2012 TSi Power Corporation. All rights reserved.

The information contained in this Document is the property of TSi Power Corporation and contains confidential and proprietary information owned by TSi Power Corporation. Any duplication or disclosure without the written approval of TSi Power Corporation is prohibited.

TRADEMARK

TSi Power, TSi, the TSi Logo and Outdoor XUPS-1500-7070 are trademarks of TSi Power Corporation.

LIMITED WARRANTY

TSi Power Corporation warrants this product to be free from defects in materials and workmanship for two (2) years from the date of purchase from TSi or its authorized representatives. TSi will repair (or at its option, replace) any defective component(s) during this warranty period.

To make a request or claim for service under this limited warranty, the original purchaser must return the product, in the original shipping container or equivalent, to TSi or its authorized agent, accompanied by a written receipt showing the date of purchase and both the model name and serial number of the product.

Warranty does not cover transportation costs. Damage by misuse, accident or unauthorized tampering of the product is not covered by the warranty. NO OTHER WARRANTIES ARE EXPRESSED OR IMPLIED. TSI IS NOT LIABLE FOR CONSEQUENTIAL DAMAGES. THIS WARRANTY GIVES YOU SPECIFIC LEGAL RIGHTS, AND YOU MAY ALSO HAVE OTHER RIGHTS WHICH VARY FROM STATE TO STATE.

LIMITATION OF LIABILITY

IN NO EVENT SHALL TSI POWER CORPORATION BE LIABLE FOR ANY DAMAGES WHATSOEVER (INCLUDING WITHOUT LIMITATION, DAMAGES FOR LOSS OF BUSINESS PROFITS, BUSINESS INTERRUPTION, LOSS OF BUSINESS INFORMATION, OR OTHER PECUNIARY LOSS) ARISING OUT OF THE USE OR INABILITY TO USE THIS PRODUCT, EVEN IF TSI OR ITS AGENT HAVE BEEN ADVISED OF THE POSSIBILITY OF SUCH DAMAGES. SOME STATES DO NOT ALLOW THE LIMITATION OR EXCLUSION OF LIABILITY FOR INCIDENTAL OR CONSEQUENTIAL DAMAGES, SO THE ABOVE EXCLUSIONS MAY NOT APPLY TO YOU.

REVISIONS

<u>ISSUE</u>	<u>DATE</u>	<u>REASON FOR REVISION</u>
1	January, 2012	First Issue.
2	February, 2012	Revised for new P/N & updates.

1. GENERAL

1.1 PRODUCT APPLICATION

The Outdoor XUPs-1500-7070 is designed specifically for powering wireless and security equipment. The product is intended for installation on a wooden or steel pole by means of a universal mounting bracket attached to the two receptacle brackets on the back of the unit. The enclosure is rain tested in accordance with applicable standards; with extra door sealing gaskets to protect the internal components against weather related problems and dust. The internal electronic circuit boards are protected by a layer of conformal coating.



Figure 1: The Outdoor XUPS-1500-7070 Cabinet

1.2 SAFETY ALERTS

SAFETY SIGNAL WORD DEFINITIONS

This document contains safety alert pictorial Symbols and Words that point out areas and procedures that require special attention with regards to safety. These Symbols and Words are defined in ANSI Z535.4-1998, Product Safety Signs and Labels.

DANGER:

DANGER *indicates an imminently hazardous situation which, if not avoided, will result in death or serious injury.*

WARNING:

WARNING *indicates a potentially hazardous situation which, if not avoided, will result in death or serious injury.*

CAUTION:

CAUTION *indicates an imminently hazardous situation which, if not avoided, may result in minor or moderate injury. It may also be used to alert against unsafe practices.*

The safety alert pictorial symbol  appears in this document to make users aware of important operating and safety concerns.

1.3 GENERAL CABINET DESCRIPTION

- Weather-proof enclosure with two access doors, separate compartments for batteries and electronics,
- Air exhaust,
- Protective cover for AC input circuit breaker and system on/off switch,
- Eight 12V, 31Ah gel batteries forming a 48V, 62Ah battery bus,
- AC input surge voltage protection circuit board,
- AC fan for cooling,
- AC input/output wiring terminals mounted on DIN-rail,
- System status display circuit board,
- Inverter, charger and AC voltage regulation transformer,
- Inverter, charger and voltage regulation main circuit board,
- AC input circuit breaker and system on/off switch,
- AC output (push to reset) circuit breaker,
- Battery bus circuit breaker,

- DB-9 status signal (alarm interface),
- Optional battery heater pads,
- optional battery heater control circuit board.

1.4 OVERALL DIMENSIONS – The Outdoor XUPS-1500-7070 cabinet is 28" (71.1cm) H x 13.5" (34.3cm) W x 15.75" (40cm) D and weighs 270 lbs. (129 kg) with eight batteries (see Figure 2).

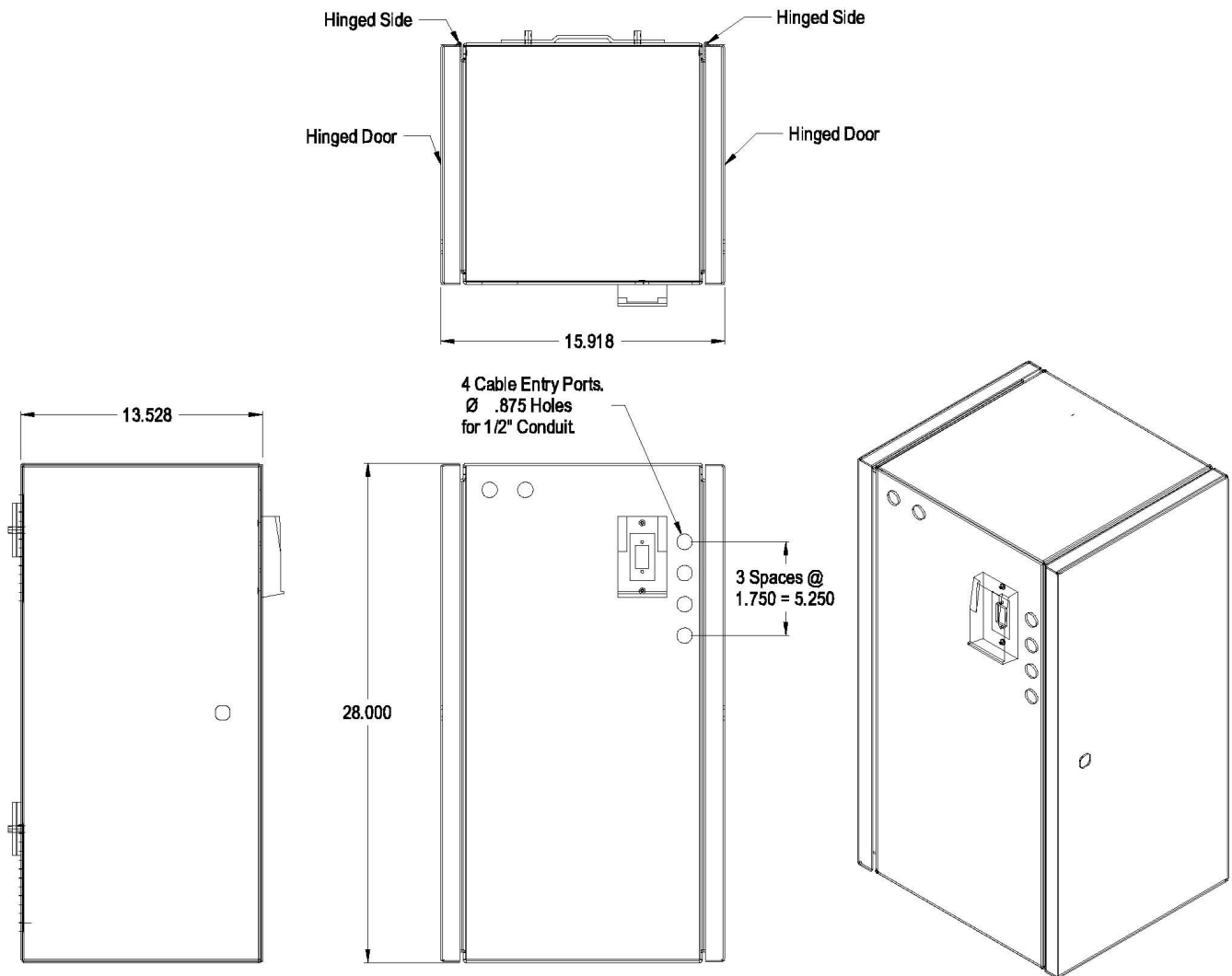

Figure 2: XUPS-1500-7070 Dimensions

1.5 CONSTRUCTION – The XUPS-1500-7070 is constructed of 5052-H32 Aluminum and finished with a black polyester powder coat that is designed to meet Telcordia specifications for protection against corrosion, water intrusion beyond NEMA 3R, UV radiation and impact resistance.

1.6 DOORS & LOCKS – The electronic and battery compartments are accessed by individual doors, each retained by two access doors and secured by a telco tool actuated, quarter –turn lock. This lock provides for proper compression gasket sealing and prevents unauthorized entry.

1.7 LEFT SIDE ACCESS

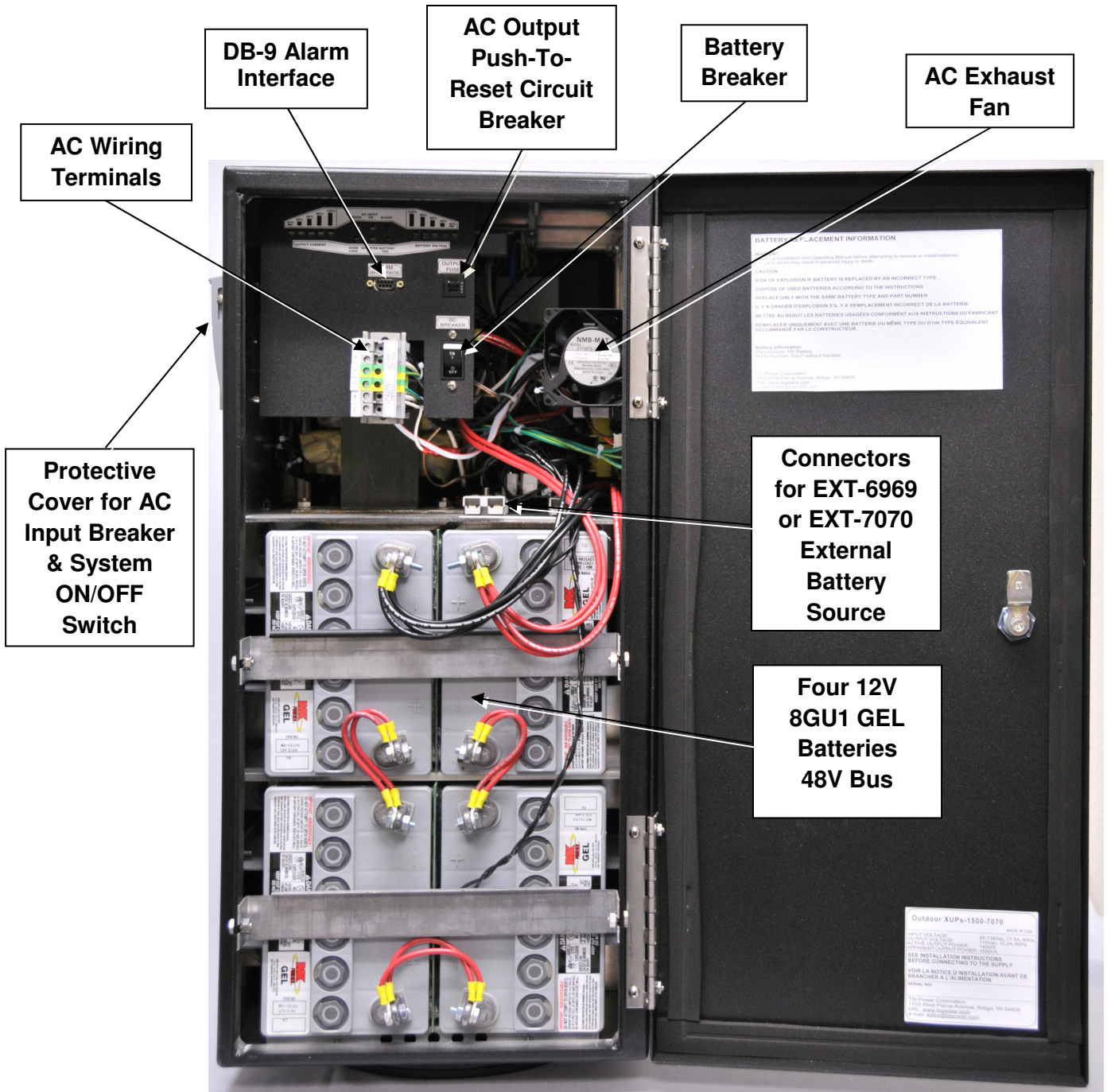

Figure 3: Electronic Compartment

1.8 RIGHT SIDE ACCESS

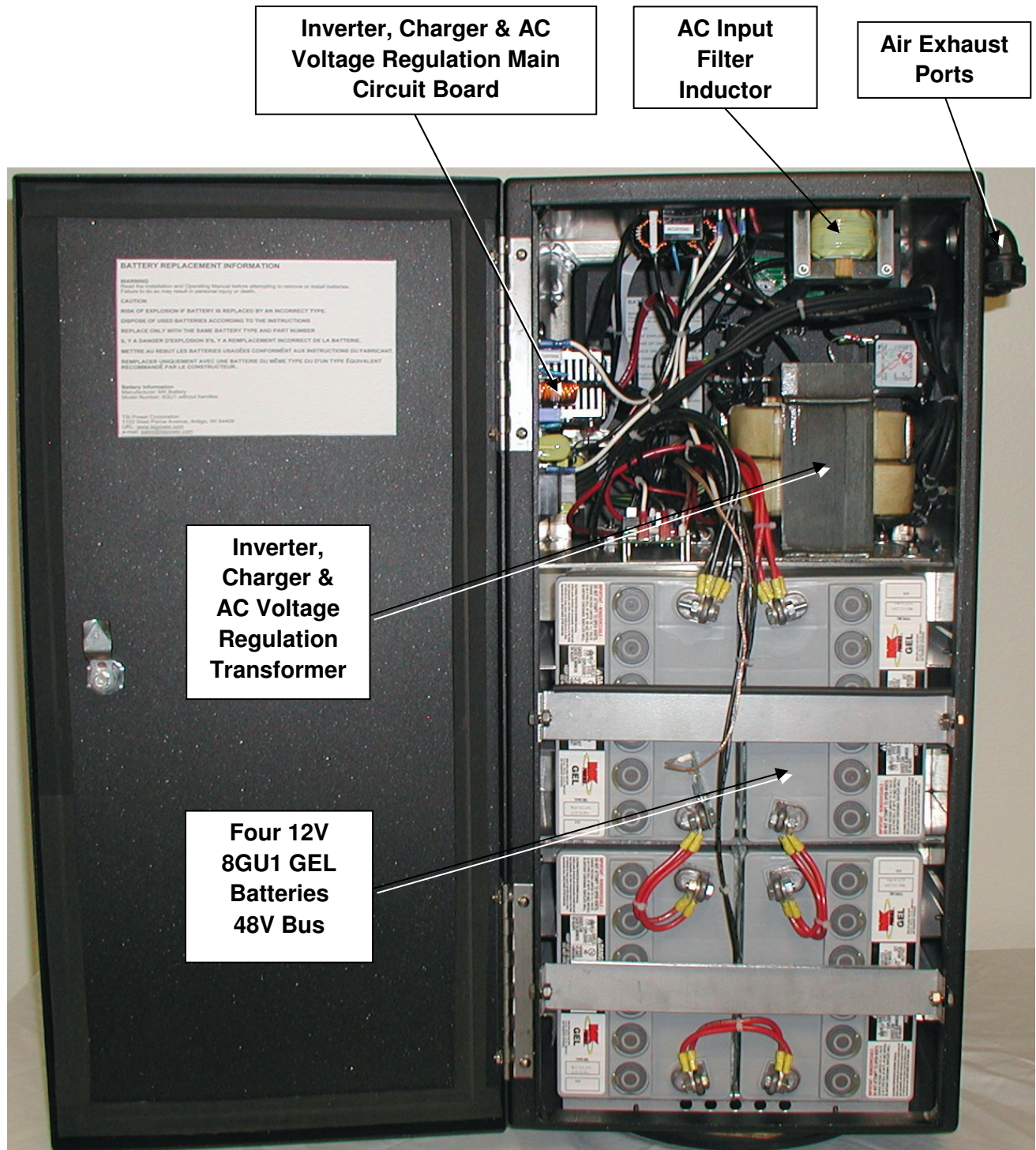

Figure 4: Electronic and Battery Compartment

2. MAJOR COMPONENT/CIRCUIT DESCRIPTIONS

2.1 XUPS WIRING DIAGRAM –

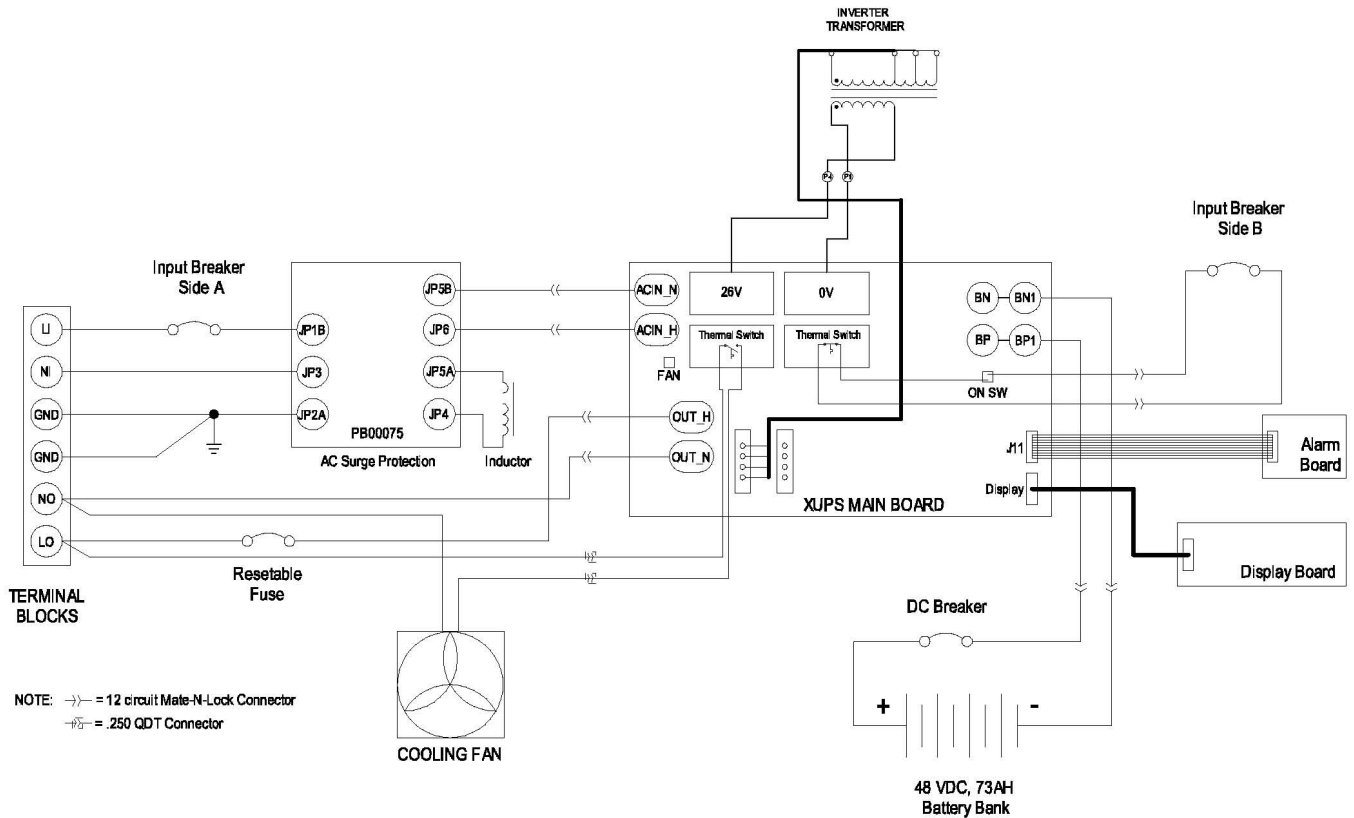

Figure 5: XUPS-1500-7070 Wiring Diagram

2.2 INVERTER, CHARGER & VOLTAGE REGULATION TRANSFORMER –

The main transformer of the XUPS, as shown in Figure 6, is connected to the main circuit board and performs three primary and unique functions:

1. It performs the Inverter, DC to AC function
2. It acts as an Auto transformer adjusting the voltage in a Buck or Boost fashion depending on the need
3. It charges the Battery Bank as required



Figure 6: Inverter & Voltage Regulation Transformer

2.3 INVERTER, CHARGING & VOLTAGE REGULATION MAIN CIRCUIT BOARD –

The proprietary main circuit board of the XUPS uses a rugged design with a microprocessor-controlled 20 kHz sine wave inverter. The design reduces the number of solid-state devices and has been conformally coated for use in severe outdoor environments. See Figure 7.

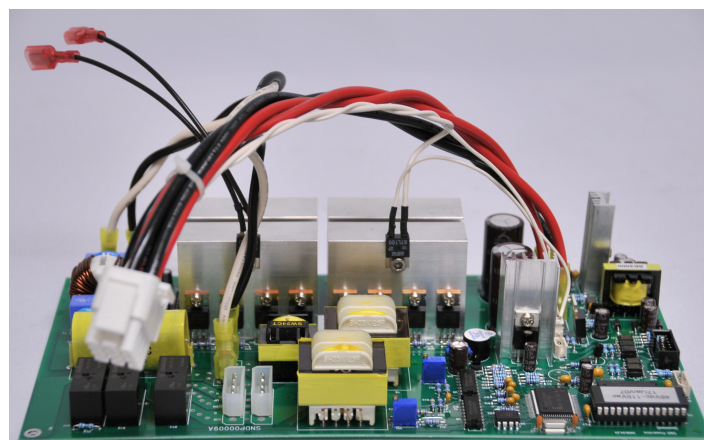

Figure 7: Main Inverter, Charging & Voltage Regulation Circuit Board

2.4 DISPLAY CIRCUIT BOARD – The display panel, pictured in Figure 8, uses the circuit board shown in Figure 9 to monitor both the output current and battery voltage.

In addition, various operating states and conditions are displayed and provide a real-time status of the XUPS' operation.

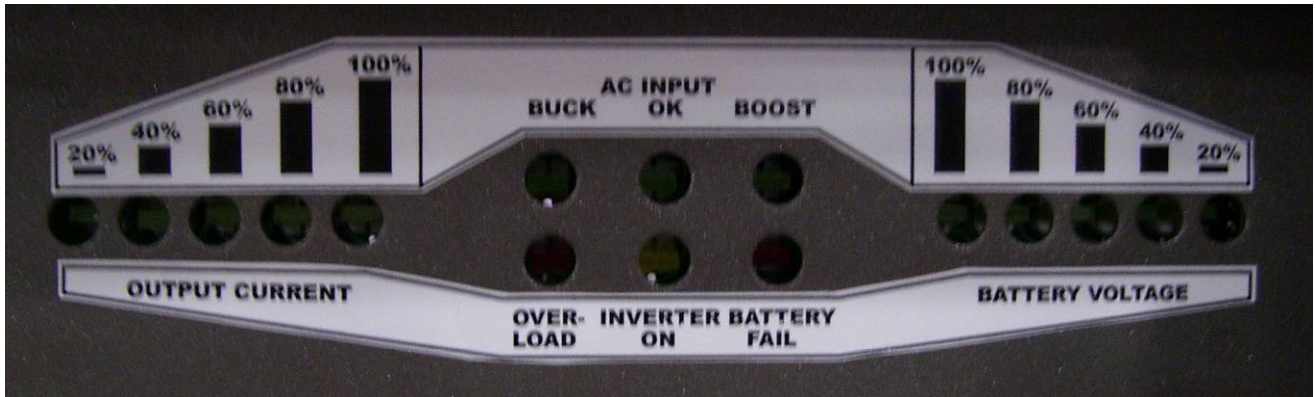

Figure 8: Panel Display Decals

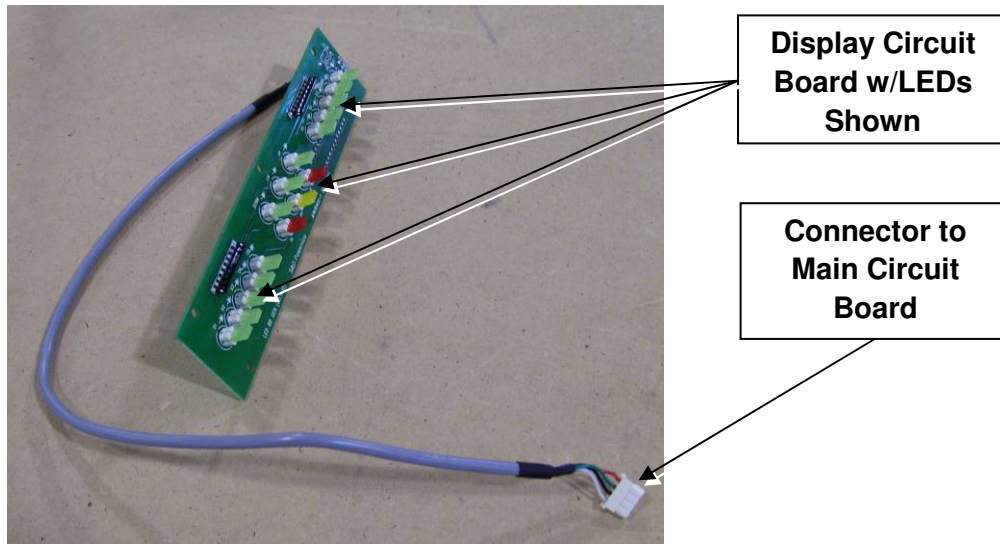

Figure 9: Display Circuit Board

2.5 ALARM CIRCUIT BOARD – Relay contact alarm signals are available through the DB-9 connector that has been soldered to the alarm circuit board. A connectorized flat cable is used to interface with the main circuit board. See Figure 10.

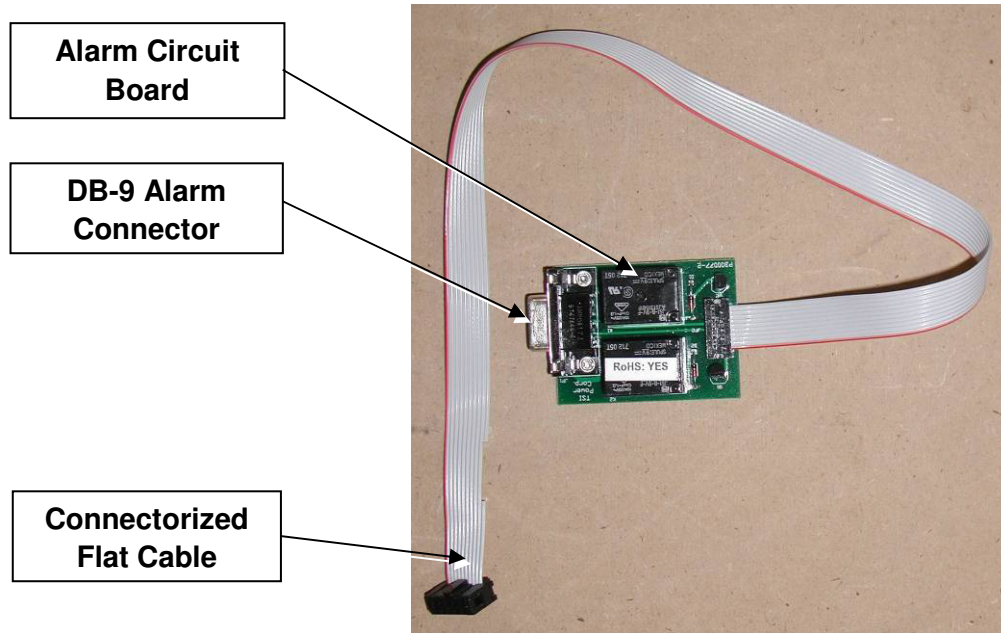

Figure 10: Alarm Circuit Board

2.6 AC SURGE PROTECTION CIRCUIT BOARD – The XUPS-1500-7070 is protected against spurious AC surge currents by a proprietary circuit board. This board uses a 40mm MOV in combination with two, 3-element gas tubes to provide protection and assure the continued function of the XUPS. See Figure 11.

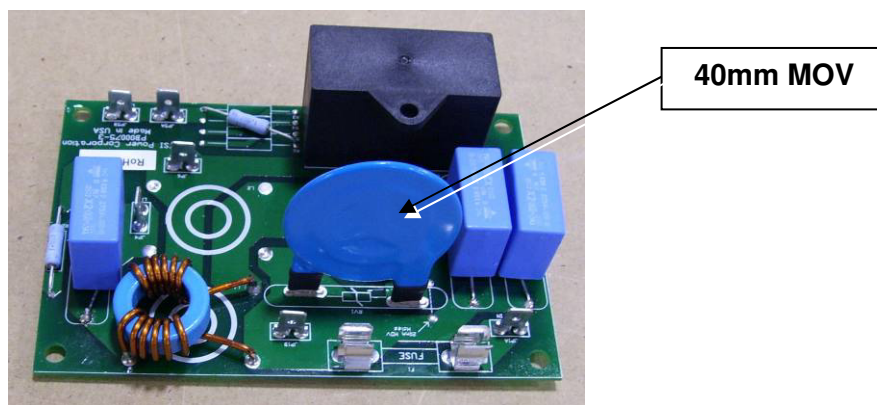

Figure 11: AC Surge Protection Circuit Board

2.7 INPUT FILTER INDUCTOR – This 1mh, iron core filter inductor is off board and is an integral part of the surge protection circuit. It filters out normal mode noise between the line and neutral branches of the incoming AC. See Figure 12.

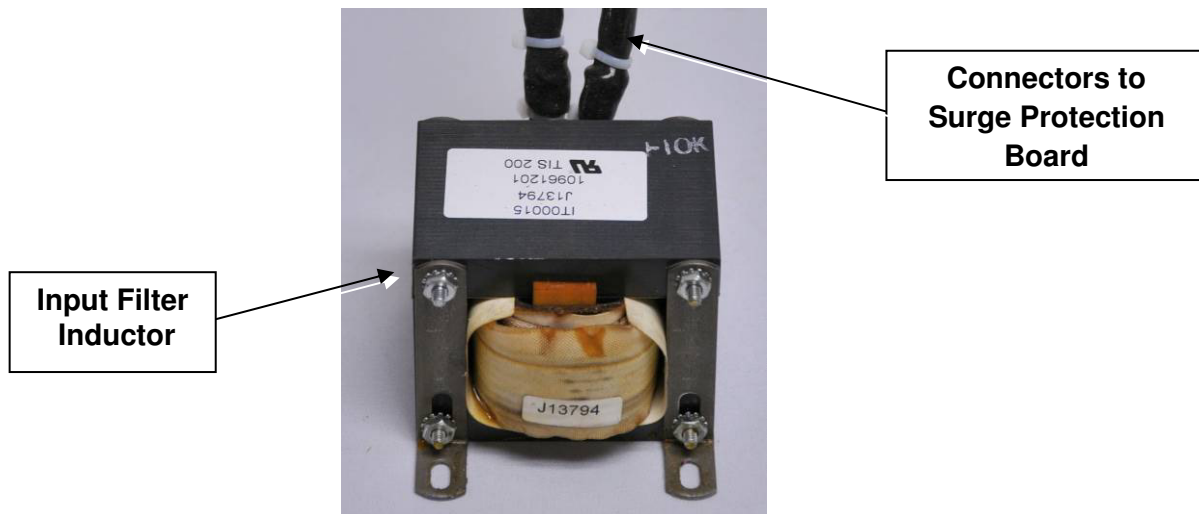

Figure 12: AC Input Filter Inductor

3. INSTALLATION

IMPORTANT: ONLY QUALIFIED PERSONNEL SHOULD PERFORM THE INSTALLATION OF THIS PRODUCT.

3.1 SITE SELECTION & PREPARATION – Although the customer will be selecting not only a site, but also installing the mounting bracket on the power pole, there are several thoughts to keep in mind when making this installation:

- This product is intended for installation in “**RESTRICTED ACCESS LOCATIONS ONLY.**”
- The cabinet should be mounted on the power pole in such a manner so that the doors don’t open onto a road or a driveway.
- Position the mounting bracket on the pole so that the cabinet rests where the cable can easily enter the cabinet from the bottom.
- If bringing in cable through a conduit up the pole, make sure that the trade size of the conduit is no larger than ½”. Larger conduit connectors will not fit the hole in the cabinet.

- Make sure that door clearances around the unit provide for unobstructed access.
- Provide a 30A, 120V service with a disconnect switch in the near vicinity of the XUPS.

3.2 REQUIRED TOOLS

- A 216-type tool to open the compartment doors
- A standard telco socket wrench set and standard mechanic telco tools
- Appropriate lifting equipment to lift and seat the unit onto the mounting bracket on the power pole [The weight with eight batteries is 270 lbs. (129 kg)]

3.3 UNPACKING & INSPECTION

3.31 The units are shipped in wooden crates, each containing two, four, eight or twelve units. The units are placed on a pallet, back-to-back, stacked if eight or twelve, with protective material between them.

3.32 Carefully open the crates, making sure not to damage the units, and remove the protective wrap and packing material.

3.33 Before the units are removed from the crates, inspect them for physical damage.

3.34 If no damage is found, remove the units from the crates, open the doors and again inspect for damage. If damage is found in either steps 3.33 or 3.34, do not accept the shipment and file a claim with the carrier. Contact TSi for assistance if necessary.

3.35  **CAUTION: The units contain charged batteries capable of causing fire and injury if shorted across terminals. Be very careful not to short terminals accidentally when unpacking.**

3.4 INSTALLING THE XUPs

3.41 After the unit has been unpacked and inspected, lift the unit onto the universal mounting bracket attached to the power pole by sliding the two receptacle brackets on the back of the XUPS into the pole bracket. See Figures 13 & 14.

 **CAUTION: Make sure that appropriate lifting equipment is used and that company safety practices are followed.**

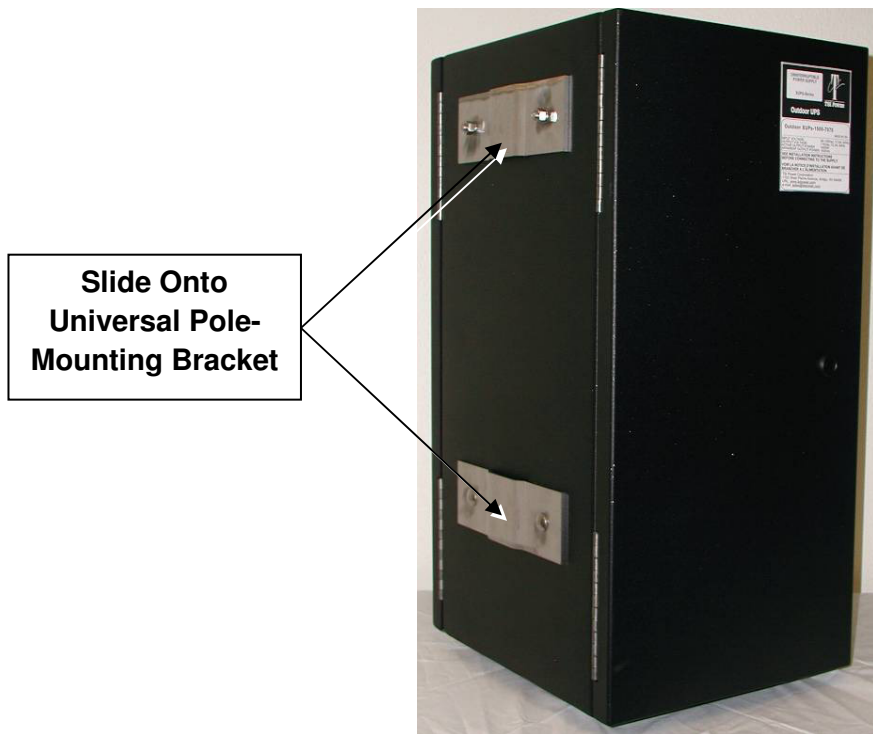

Figure 13: XUPs Rear Mounting Brackets

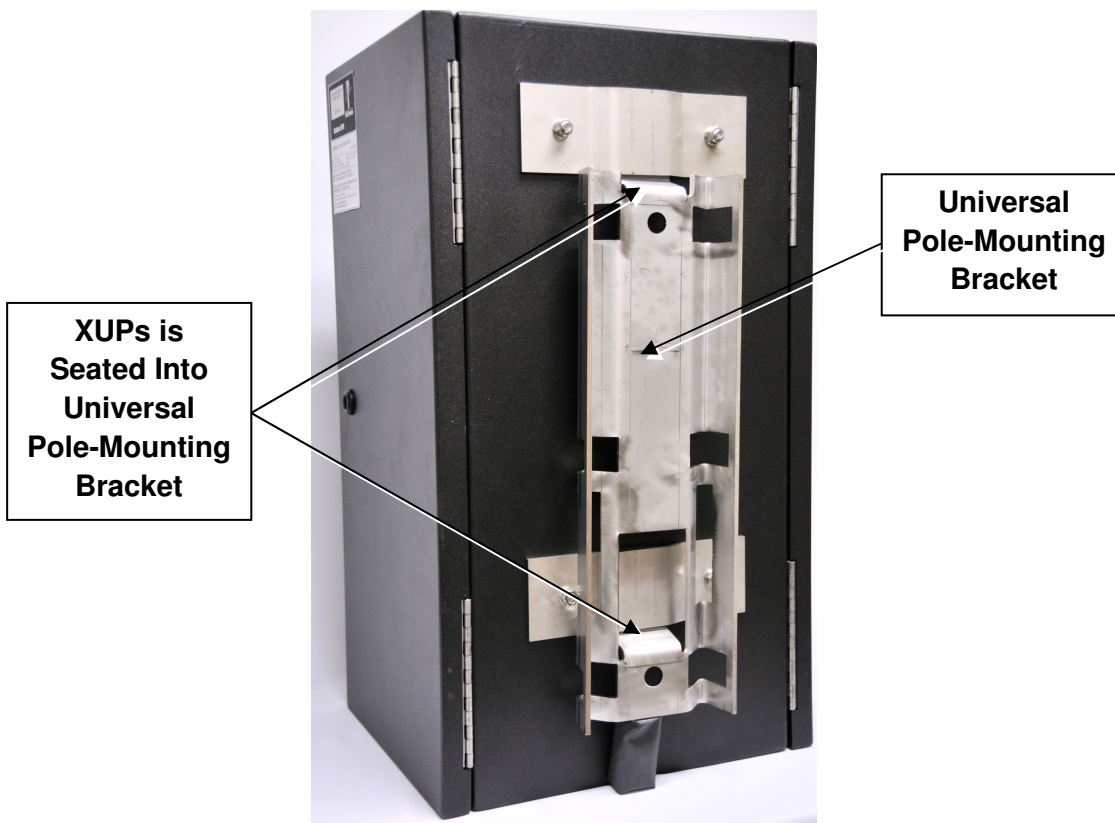

Figure 14: Universal Pole-Mounting Bracket

3.42 Check to ensure that the XUPS is securely seated all the way into the universal pole mounting bracket. See Figure 14.

3.43 As a final step before powering up the unit, make sure that the air inlet and exhaust ports are free of obstruction to prevent overheating.

4. POWERING UP THE XUPS

4.1 AC INPUT CONNECTIONS

4.11 Make sure that an AC, 30A, 120V service with a disconnect switch is provided near the XUPS and make sure that it is switched **OFF**.

4.12 If bringing in cable through a conduit up the pole, make sure that the size of the conduit is ½” and not larger. Larger conduit connectors will not fit through the entry holes. See Figure 15 for cable entry and exit holes in the bottom of the electronic compartment.

4.13 Use 12 AWG wire with a 105°C insulation system for all conductors.

4.14 Allow for sufficient wire length to reach the wiring terminals and leave enough slack to reduce the stress in the wires.

4.15 Strip approximately 3/8” (9.5mm) insulation from the end of each of the six (6) input/output AC wires and terminate them in the wiring terminals in the lower left side of the electronics compartment. See Figure 15.

4.16 Terminate the Incoming wires on the terminals marked as shown in Figure 15 and as follows:

- **LI** is for phase conductor (black)
- **NI** is for neutral conductor (white)
- **G** is for safety ground

4.16 Terminate the Outgoing wires on the terminals marked as shown in Figure 15 and as follows:

- **LO** is for phase conductor (black)
- **NO** is for neutral conductor (white)
- **G** is for safety ground
-

4.17 In terminating the wires as outlined in 4.15 & 4.16 above, use a slotted screwdriver to tighten the terminal screws until the wires are secure. Do not apply excessive torque to make sure that the terminal screws are not damaged. Once screws have been tightened, gently tug on the wires to make sure that they are properly connected.

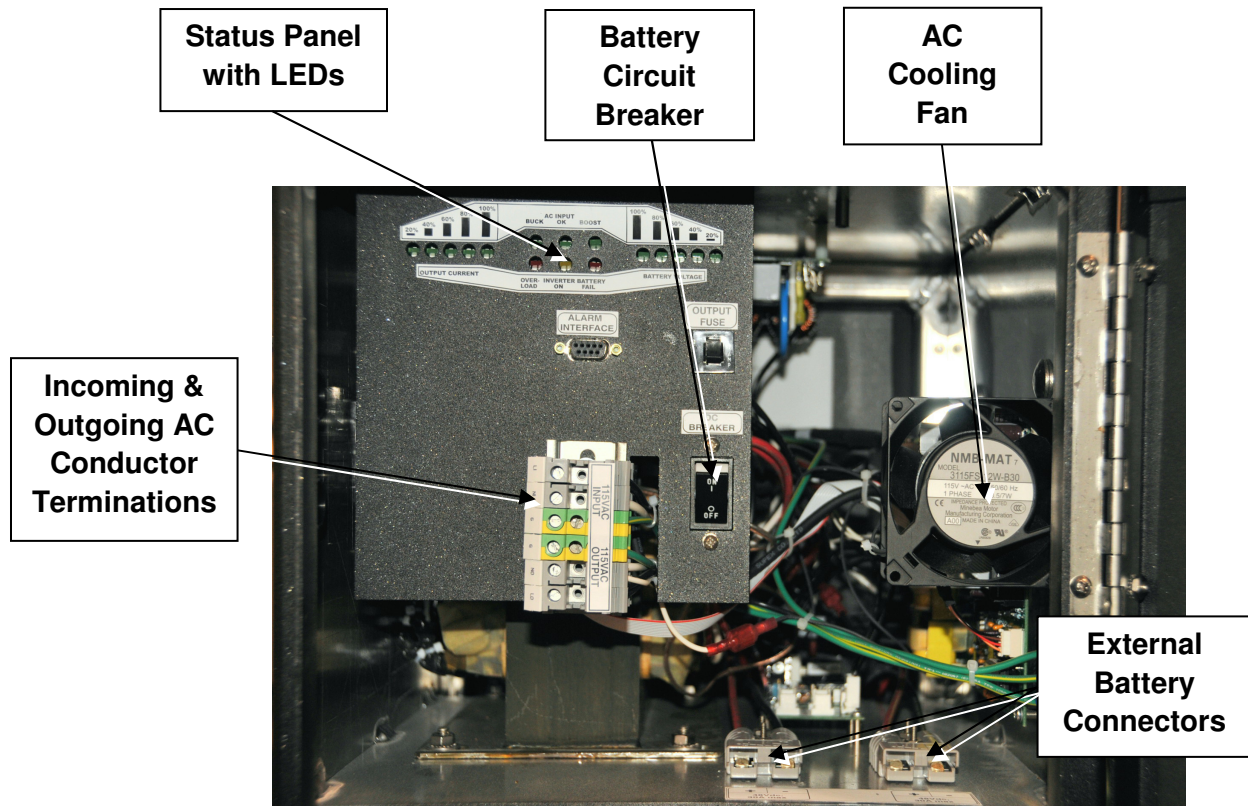

Figure 15: Incoming & Outgoing Wire Terminations

4.17 In terminating the wires as outlined in 4.15 & 4.16 above, use a slotted screwdriver to tighten the terminal screws until the wires are secure. Do not apply excessive torque to make sure that the terminal screws are not damaged. Once screws have been tightened, gently tug on the wires to make sure that they are properly connected.

4.18 **▲ WARNING: TO PREVENT DAMAGE MAKE SURE TO CHECK THAT THE INPUT & OUTPUT WIRES ARE NOT REVERSED**

4.2 ENERGIING THE XUPS – The following steps outline the procedures for putting the XUPs into operation:

4.21 Turn on the AC, 30A, 120V service by putting the disconnect switch to the **ON** position.

4.22 Switch on the battery circuit breaker.

- 4.23** Open the protective outside box cover and switch on the AC input circuit breaker.
- 4.24** Verify that all LEDs on the status display panel (see Figure 8) illuminate one by one. This may take approximately five (5) seconds.
- 4.25** Verify that the following LEDs are illuminated:
1. Verify that the **AC INPUT OK** is illuminated.
 2. Check the **Battery Voltage LEDs** located on the right side.
 - When **five (5) LEDs are on**, it means that the **batteries are fully charged**.
 - When **one (1) LED is on**, it means that the **batteries are discharged**.
 3. Check the **Load Current LEDs** located on the left side.
 - When **five (5) LEDs are on**, it means that the **unit is fully loaded**.
 - When **one (1) LED is on**, it means that the **unit is seeing a very light load**.
 4. Verify that the **Red LEDs** that indicate **Overload & Battery Fail** are **OFF**.
 5. Verify that the **Amber LED** that indicates **Inverter ON** is **OFF**.
 6. **THE SYSTEM IS NOW READY FOR OPERATION.**

5. MAINTAINING THE XUPs-1500-7070

To make sure that the unit is functioning properly and safely, check the following periodically or at least once a year:

5.1 XUPs OPERATION

- 5.11** Switch-off disconnect.
- 5.12** Verify that the XUPs operates in **Inverter Mode** with **Amber LED ON**.
- 5.13** Switch-Off the AC input circuit breaker and check the operation of the AC fan. Replace if necessary.

5.2 CABINET INTEGRITY

- 5.21** Check the air intake and exhaust for dust and debris. Remove as required.
- 5.22** Check for moisture and water accumulation and remove as necessary.

- 5.23** Check to make sure locks are functioning properly and have not been vandalized. Replace if necessary.
- 5.24** Check gasketing to make sure that door seals are still tight and effective. Replace if necessary.
- 5.3 BATTERY MAINTENANCE** – See Section 6 for battery replacement.
- 5.31** Check the batteries for electrolyte leakage. Clean up and replace if necessary.
- 5.32** Disconnect battery cable from battery to be checked. Measure the battery terminal voltage of all batteries. Each battery should have a terminal voltage of 13.5Vdc \pm 0.3V. Replace **All** batteries if the difference is larger than \pm 0.3V.

6. TROUBLESHOOTING & COMPONENT REPLACEMENT

- 6.1 STATUS ALARMS** – Relay contact status alarm signals are available through the DB-9 connector located in the top left corner of the electronics compartment. See Figure 16. The following output pins have been assigned:
- 6.11** Pins 6 & 7 signify “Closed relay contact when inverter is ON (open when OFF)”.
- 6.12** Pins 8 & 9 signify “Open relay contact when battery bus voltage is OK > 44Vdc.
Relay contact closes when battery bus voltage is < 44Vdc.”

6.2 REPLACING BATTERIES

 **DANGER:** The servicing or replacement of batteries should be restricted to qualified and experienced personnel.

- Use extreme care when handling the batteries.
- When lifting the batteries wear heavy gloves and safety glasses at all times.
- Do not wear rings, watches, metal wrist bands, or bracelets.
- Do not allow metal objects to come in contact with the terminal side of the batteries.
- Use tools with insulated handles.
- Disconnect charging source prior to connecting or disconnecting battery terminals.
-

- **Determine if battery is inadvertently grounded. If inadvertently grounded, remove source from ground. Contact with any part of a grounded battery can result in electric shock. The likelihood of such shock can be reduced if such grounds are removed during installation and maintenance.**

▲ CAUTION: Do not dispose of batteries in a fire. The batteries may explode.

▲ CAUTION: Do not open or mutilate batteries. Released electrolyte is harmful to the skin and eyes. It may be toxic.

▲ CAUTION: A battery can present a risk of electric shock and high short-circuit current.

AVERTISSEMENT: Ne jetez pas les batteries dans un feu. Elles pourraient exploser.

AVERTISSEMENT: N'ouvrez pas et n'altérez pas physiquement les batteries. La solution électrolyte qui sera libérée est dangereuse pour la peau et des yeux. Elle pourrait même être toxique.

ATTENTION: Une batterie peut présenter un risque de décharge électrique et un fort courant de court-circuit.

6.21 The two battery compartments each hold four (4) 31Ah, 8GU1, MK Batteries. See Figure 16.

6.22 Only 8GU1-MU-1SLDG (without handle) sealed, valve-regulated gel batteries made by MK Battery should be used. The TSi part number for the battery is VB00010.

6.23 The following battery replacement procedure should be followed:

- Turn off AC circuit breaker,
- Turn off external disconnect,
- Turn off DC circuit breaker,
- Open door to battery compartment,
- Loosen terminal bolts,
- Remove ring terminal connections one by one and save hardware,
- Set battery jumpers aside,
- Remove battery brackets.
- Pull out old batteries carefully, set them aside,
- If heating pads are used, set them aside,
- Install new batteries. If heating pads are used, follow the instructions shown in section 7.
- Reinstall battery brackets,
- Connect battery jumpers and cables using the hardware that came with the new batteries. Tighten bolts and nuts lightly.

- Torque bolts in accordance with battery manufacturer's specifications.

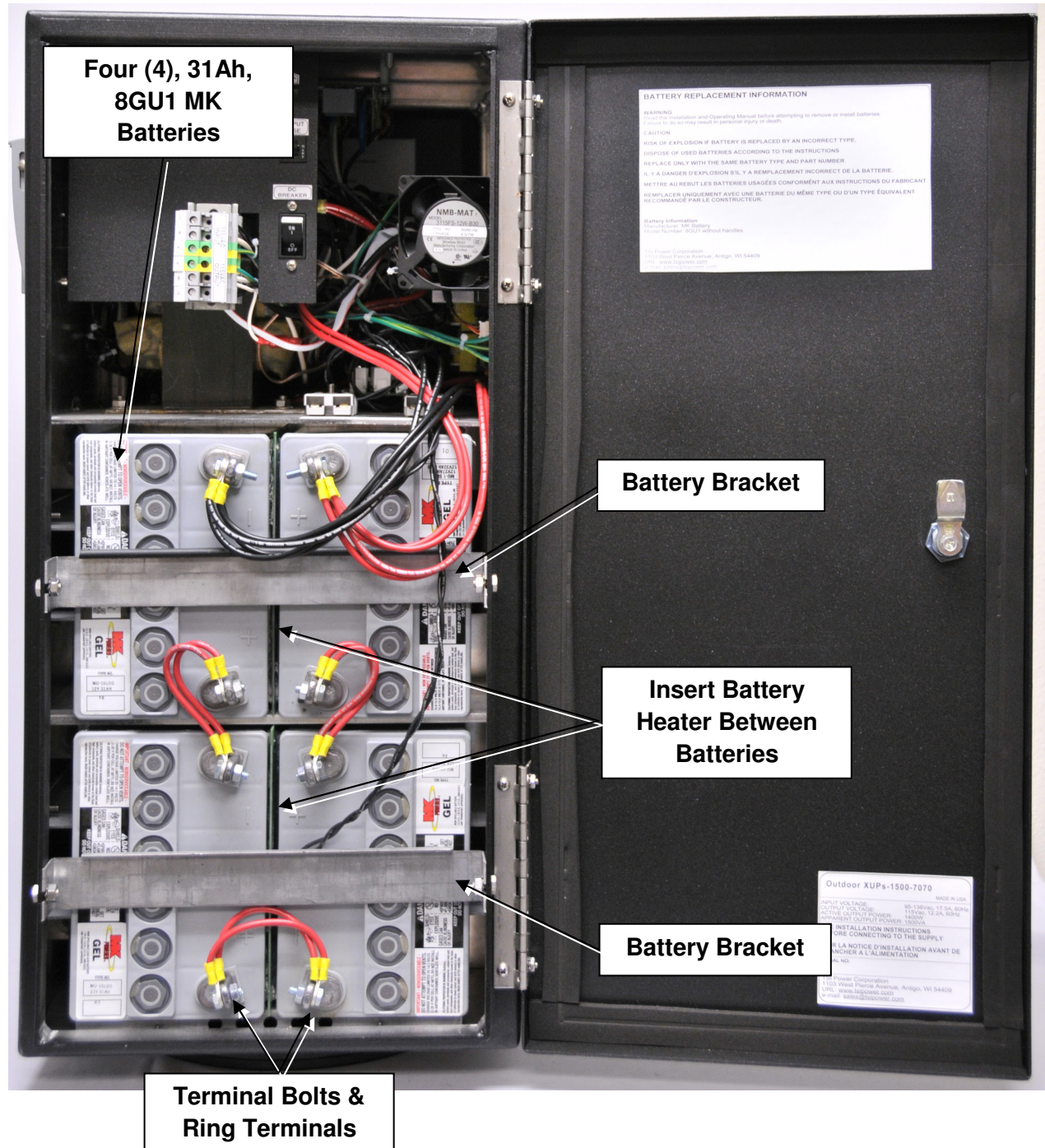

Figure 16: Batteries Shown in Open Battery Compartment

- Check all connections,
- Reenergize system,
- Dispose of old batteries in accordance with battery manufacturer's instructions.

7. OPTIONAL EQUIPMENT

7.1 OPTIONAL BH5 BATTERY HEATER – The optional battery heating pads are constructed from printed circuit boards with resistor networks that are encapsulated in epoxy. The AC current flows through the resistors to generate heat. By being pressed against both internal walls of the batteries, the batteries are heated. The standard Outdoor XUPs-1500-7070 requires four BH5 battery heaters. See Figure 17.

Installation of the heater pads is as follows:

- Turn the AC circuit breaker off,
- Turn the DC circuit breaker off,
- Remove connections between batteries (save hardware),
- Remove battery brackets,
- Remove batteries by pulling them out of compartment,
- Remove "bumpons" from either side of compartment,
- Push both batteries gently into compartment, form a wedge,
- Insert heating pad between batteries,
- Push batteries back in,
- The heating pad should now be secure between the batteries,
- Replace battery brackets,
- Run the wires back to the heater control PCB and mate connector with header.
- Restart the XUPs.

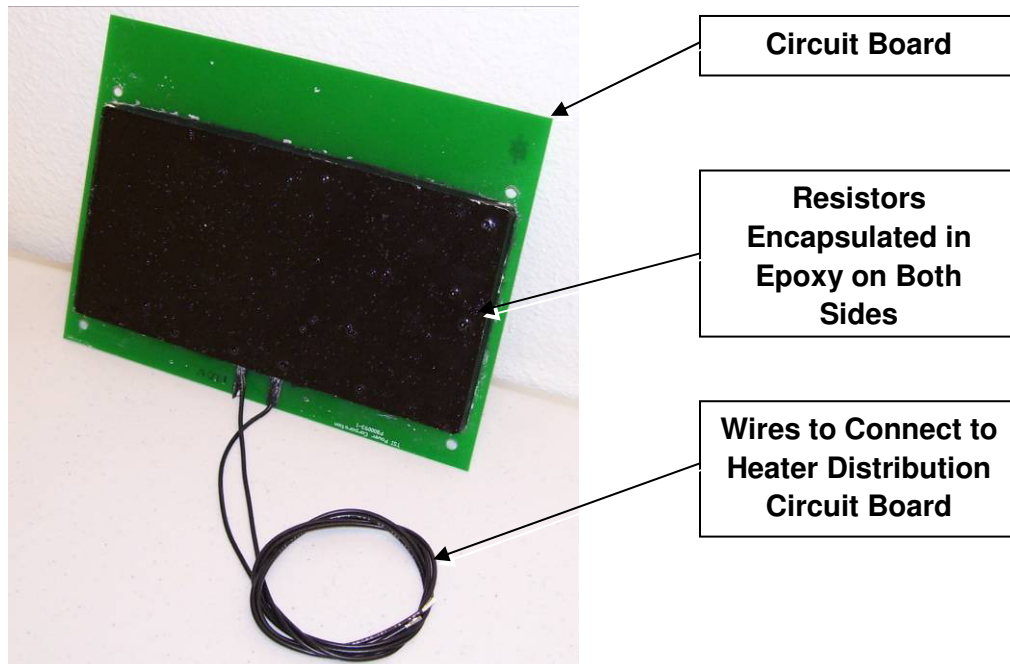

Figure 17: Optional BH5 Battery Heater

8. REPAIRS, SERVICE & SPARE PARTS

8.1 REPAIRS - The Outdoor XUPs-1500-7070 should only be repaired by persons with knowledge of power electronics and electrical safety procedures. Others should contact TSi Power Corporation for a Return Material Authorization (RMA). The TSi service representative will determine if factory repair is necessary and issue an RMA, if required. A replacement unit will be shipped to certain customers with service agreements. TSi retains the repaired unit.

8.2 SPARE PARTS - The table below contains information on replaceable parts that can be ordered from TSi if necessary.

Description	TSi Part Number	Manufacturer	Mfg. Part No.
Inverter PCB	PZ00080-1C	TSi Power	N/A
Input protection PCB	PB00075-3C	TSi Power	N/A
Alarm PCB	PB00077-1C	TSi Power	N/A
Display PCB	PZ00078-1C	TSi Power	N/A
Heater Control PCB	PZ00098-1C	TSi Power	N/A
Heater	BH5	TSi Power	N/A
Input inductor	IT00015	Johnson Electric Coil	J13794
Inverter transformer	TP00213	Johnson Electric Coil	J14613
AC input breaker	FC00063	Airpax	IEGBX66-1-62-20.0-M3-V
Battery breaker	FC00093	Airpax	IELBX1-1-72-60.0-M3-V
Output breaker	FC00015	Tyco Electronics	W28-XQ1A-15
AC cooling fan	VF00015	Minebea	3115FS-12T-B30
31Ah battery	VB00010	MK Battery	8GU1

9. REFERENCE

9.1 SPECIFICATIONS

Input	
Voltage Range	95 to 140Vac
Voltage Regulation	115Vac \pm 8%
Frequency	60Hz \pm 5%
Current (600/1000) max charging @ low line	17.8A
Circuit Breaker (600/1000)	20A
Output	
Output Power	1400W
Power Factor (True non-displacement)	0.7
Current @ low line	11.6A
Waveform & Harmonic Distortion	Sinusoidal, <3% THD
Power Efficiency in AC Line Mode	>94%
Power Efficiency in Inverter Mode	>93%
Transfer Time AC Line to Inverter	<4ms
Circuit Breaker	15A, 0.75 derated @ 55°C
Battery	
Type	Eight sealed 12Vdc gel, valve-regulated, lead-acid, maintenance free (sold separately)
Temperature	Fully charged: -60°C to 60°C
Capacity	31Ah @ 20 hour rate per battery
Circuit Breaker (600/1000)	60A
Weight (lb/kg)	23/10.5

Dimensions (in/mm)	7.71L x 5.18W x 7.22H/196L x 132W x 183H
Runtime	1.1hrs @ 1400W
Recharge Time	15hrs to 90% after full discharge
Battery Heater Pad	34W
LED Indicators	
Output OK	Green, Solid
Inverter ON	Yellow, Solid
AC Voltage Regulation Buck-Boost	Green, Solid
Replace Battery	Red, Solid
DC Input Voltage Level	Green, 1 - 5 LEDs, Low to Max
Output Current Level	Green, 1 - 5 LEDs, Low to Max
Overload	Red, Solid
Mechanical	
Dimensions (in/mm)	13.5W x 15.75D x 28H / 343W x 400D x 711H
Weight, with/without batteries (lb/kg)	270/129 123/59
Environmental	
Operating Temperature* (with heater)	-40°C to 45°C
Operating Temperature** (without heater)	-10°C to 45°C
Storage Temperature	-60°C to 60°C
Humidity	0 to 95% non-condensing
* Duration of storage will determine the need for supplemental charge, especially at elevated temperatures.	
** Extended exposure to temperatures >40°C may shorten battery life.	
Mounting Configuration	

Universal pole-mount bracket, part number: ZC00497
Agency Compliance
Designed to FCC part 15 Class B
Designed to UL 1778 Fourth Edition and CSA C22.2 No. 107.3-05
RoHS compliant, per EU Directive 2002/95/EC, Restrictions of Hazardous Substances
Rain tested to UL 50

9.2 PRODUCT CONFIGURATION - The table below shows different product configurations. Each configuration is identified by a two digit suffix that follows the last four (4) digits of the basic Outdoor XUPs-600/1000-6969, i.e., Outdoor XUPs-600/1000-6969-00.

Suffix	Configuration	Comments
00	No batteries, no heater	User supplied batteries
10	Two batteries, no heater	
20	Four batteries, no heater	
01	No batteries, one heater	User supplied batteries
02	No batteries, two heaters	User supplied batteries
11	Two batteries, one heater	
22	Four batteries, two heaters	

9.3 TSi POWER CONTACT INFORMATION

TSi Power Corporation
1103 West Pierce Avenue
Antigo, WI 54409, USA
Toll-Free Tel: 800-874-3160 (for USA & Canada only)
Tel: +1-715-623-0636
Fax: +1-715-623-2426
URL: www.tsipower.com E-mail: sales@tsipower.com