



**TSI**  
POWER™

**Operating Manual for:**

**VRP, Split Phase, 3.8 kVA – 44.9 kVA**

**MC60025**

**January, 2024**

**IMPORTANT SAFETY INSTRUCTIONS:** SAVE THESE INSTRUCTIONS – This manual contains important instructions for the split phase VRP Series that should be followed during installation and maintenance.

<b>Table of Contents</b>	<b>Page</b>
<b>1. GENERAL</b>	<b>5</b>
1.1 PRODUCT APPLICATION.....	5
1.2 SAFETY ALERTS.....	6
1.3 GENERAL VRP DESCRIPTION.....	6
1.4 OVERALL DIMENSIONS .....	7
1.5 CONSTRUCTION.....	8
1.6 VRP ENCLOSURE TOP VIEW WITH COVERS REMOVED .....	9
1.7 LARGE SERIES (24in. Cube) HARDWIRE ACCESS .....	11
1.8 XLARGE SERIES (32in. Cube) HARDWIRE ACCESS.....	12
<b>2. MAJOR COMPONENT/CIRCUIT DESCRIPTIONS</b>	<b>13</b>
2.1 SPLIT PHASE VRP WIRING DIAGRAMS.....	13
2.2 BUCK-BOOST VOLTAGE REGULATION TRANSFORMERS .....	15
2.3 CONTROL CIRCUIT BOARD ASSEMBLY.....	16
2.4 SURGE/FILTER BOARD ASSEMBLIES .....	17
2.5 VRP STATUS INDICATORS.....	19
2.6 VRP INTERNAL CIRCUIT BREAKER.....	20
2.7 VRP INPUT EMI FILTER .....	20
2.8 VRP UNIT EXHAUST FAN .....	21
2.9 VRP HEAT SINK COOLING FAN .....	21

<b>3.</b>	<b>INSTALLATION</b>	<b>22</b>
3.1	SITE SELECTION & PREPARATION.....	22
3.2	REQUIRED TOOLS.....	22
3.3	UNPACKING & INSPECTION.....	22
3.4	INSTALLING THE VRP.....	23
3.5	AC CONNECTIONS (HARDWIRE VERSIONS).....	23
<b>4.</b>	<b>POWERING UP THE VRP</b>	<b>25</b>
4.1	CHECKING FOR PROPER INPUT VOLTAGE.....	25
4.2	ENERGIZING THE VRP.....	25
<b>5.</b>	<b>MAINTAINING THE VRP</b>	<b>26</b>
5.1	VRP OPERATION.....	26
5.2	ENCLOSURE INTEGRITY.....	26
<b>6.</b>	<b>TROUBLESHOOTING &amp; COMPONENT REPLACEMENT</b>	<b>26</b>
6.1	VISUAL STATUS INDICATORS.....	26
6.2	DECOMMISSIONING THE VRP & INSPECTING FOR DAMAGE.....	27
<b>7.</b>	<b>REPAIRS, SERVICE &amp; SPARE PARTS</b>	<b>27</b>
7.1	REPAIRING VRP.....	27
7.2	REPAIRING THE VRP IN THE FIELD.....	28
7.3	SPARE PARTS.....	29
7.4	REPLACEMENT OF HEAT SINK COOLING FAN.....	29
7.5	REPLACEMENT OF MAIN CONTROL BOARD ASSEMBLY.....	29
7.6	REPLACEMENT OF UNIT EXHAUST FAN.....	30
<b>8.</b>	<b>CONTACT INFORMATION</b>	<b>30</b>
8.1	TSI CONTACT INFORMATION.....	30

## **COPYRIGHT**

Copyright © 2024 TSI Power Corporation. All rights reserved.

The information contained in this Document is the property of TSI Power Corporation and contains confidential and proprietary information owned by TSI Power Corporation. Any duplication or disclosure without the written approval of TSI Power Corporation is prohibited.

## **TRADEMARK**

TSI Power, TSI, the TSI Logo and VRP Series are trademarks of TSI Power Corporation.

## **LIMITED WARRANTY**

TSI Power Corporation warrants this product to be free from defects in materials and workmanship for two (2) years from the date of purchase from TSI Power or its authorized representatives. TSI will repair (or at its option, replace) any defective component(s) during this warranty period.

To make a request or claim for service under this limited warranty, the original purchaser must return the product, in the original shipping container or equivalent, to TSI Power or its authorized agent, accompanied by a written receipt showing the date of purchase and both the model name and serial number of the product.

Warranty does not cover transportation costs. Damage by misuse, accident or unauthorized tampering of the product is not covered by the warranty. NO OTHER WARRANTIES ARE EXPRESSED OR IMPLIED. TSI IS NOT LIABLE FOR CONSEQUENTIAL DAMAGES. THIS WARRANTY GIVES YOU SPECIFIC LEGAL RIGHTS, AND YOU MAY ALSO HAVE OTHER RIGHTS WHICH VARY FROM STATE TO STATE.

## **LIMITATION OF LIABILITY**

IN NO EVENT SHALL TSI POWER CORPORATION BE LIABLE FOR ANY DAMAGES WHATSOEVER (INCLUDING WITHOUT LIMITATION, DAMAGES FOR LOSS OF BUSINESS PROFITS, BUSINESS INTERRUPTION, LOSS OF BUSINESS INFORMATION, OR OTHER PECUNIARY LOSS) ARISING OUT OF THE USE OR INABILITY TO USE THIS PRODUCT, EVEN IF TSI POWER OR ITS AGENT HAVE BEEN ADVISED OF THE POSSIBILITY OF SUCH DAMAGES. SOME STATES DO NOT ALLOW THE LIMITATION OR EXCLUSION OF LIABILITY FOR INCIDENTAL OR CONSEQUENTIAL DAMAGES, SO THE ABOVE EXCLUSIONS MAY NOT APPLY TO YOU.

## **REVISIONS**

<b><u>REV.</u></b>	<b><u>DATE</u></b>	<b><u>REASON FOR REVISION</u></b>
1	January, 2024	Initial release

## 1 GENERAL

### 1.1 PRODUCT APPLICATION

The VRP is a highly sophisticated automatic precision AC voltage regulator that ensures maintenance free operation of electronic equipment over a very wide input voltage range. TSI Power's VRP series is designed to provide high precision power with industry leading response time of one-half line cycle (10 ms or less). Common applications include but are not limited to: graphics, broadcast, telecom, industrial, analytical equipment and digital copiers. The VRP series of products may provide enhanced operation, extended operating life, reduced downtime and lower service costs.



**Figure 1: The VRP Enclosures**

**IMPORTANT SAFETY INSTRUCTIONS:** SAVE THESE INSTRUCTIONS – This manual contains important instructions for the split phase VRP Series that should be followed during installation and maintenance.

## 1.2 SAFETY ALERTS

### SAFETY SIGNAL WORD DEFINITIONS

This document contains safety alert pictorial Symbols and Words that point out areas and procedures that require special attention with regards to safety. These Symbols and Words are defined in ANSI Z535.4-1998, Product Safety Signs and Labels.

#### **DANGER:**

***DANGER indicates an imminently hazardous situation which, if not avoided, will result in death or serious injury.***

#### **WARNING:**

***WARNING indicates a potentially hazardous situation which, if not avoided, will result in death or serious injury.***

#### **CAUTION:**

***CAUTION indicates an imminently hazardous situation which, if not avoided, may result in minor or moderate injury. It may also be used to alert against unsafe practices.***

The safety alert pictorial symbol  appears in this document to make users aware of important operating and safety concerns.

## 1.3 GENERAL VRP DESCRIPTION

- Enclosure with access panel for Hardwire terminations
- Vented base and sides for cooling
- AC input over voltage protection circuit board
- AC fans for cooling
- System status display LEDs
- AVR control circuit board
- AC input circuit breaker and system on/off switch, not present in XLarge (32in. Cube) units

**1.4 OVERALL DIMENSIONS** -See Figures 2 and 3

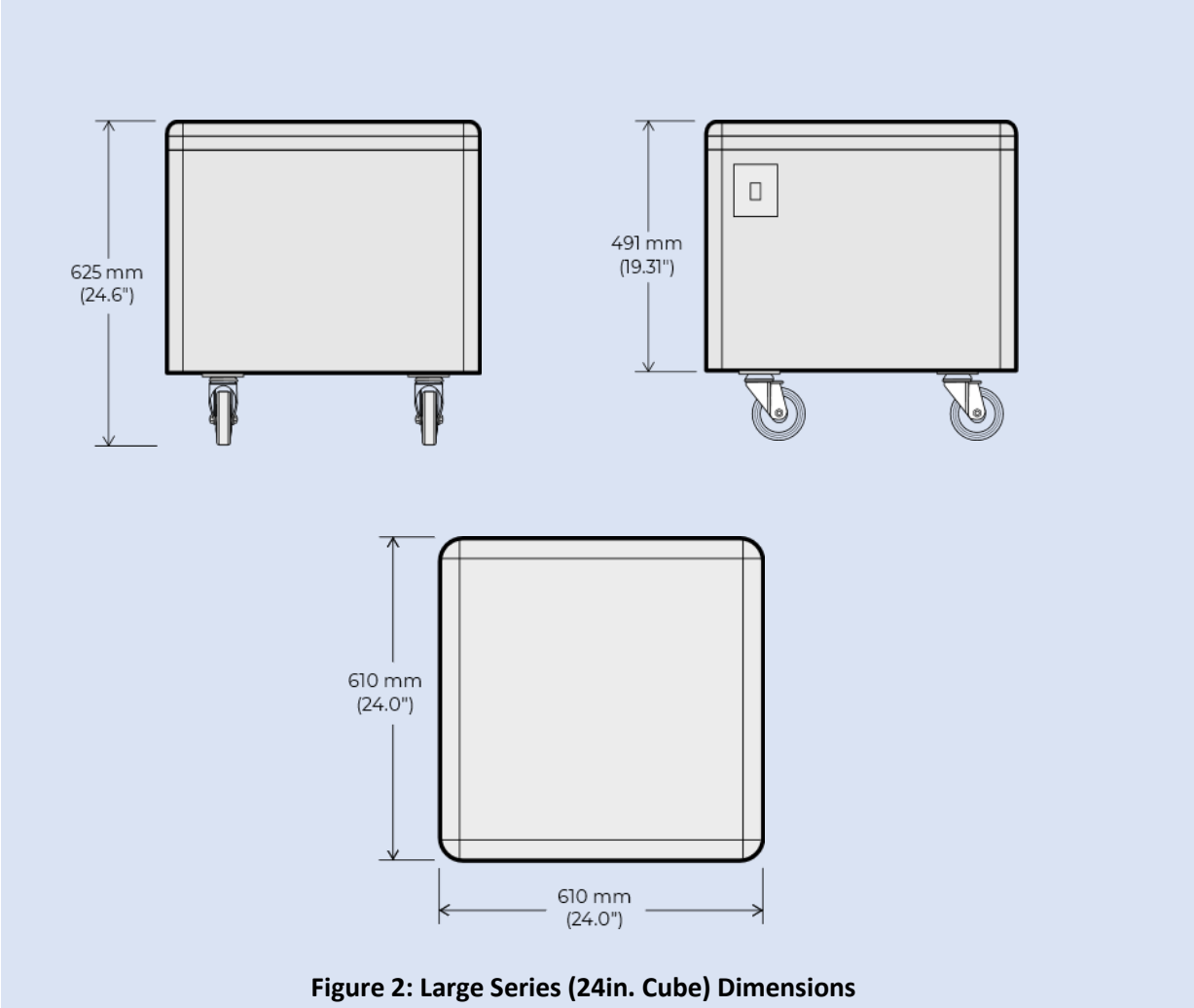

**Figure 2: Large Series (24in. Cube) Dimensions**

**Dimensions**

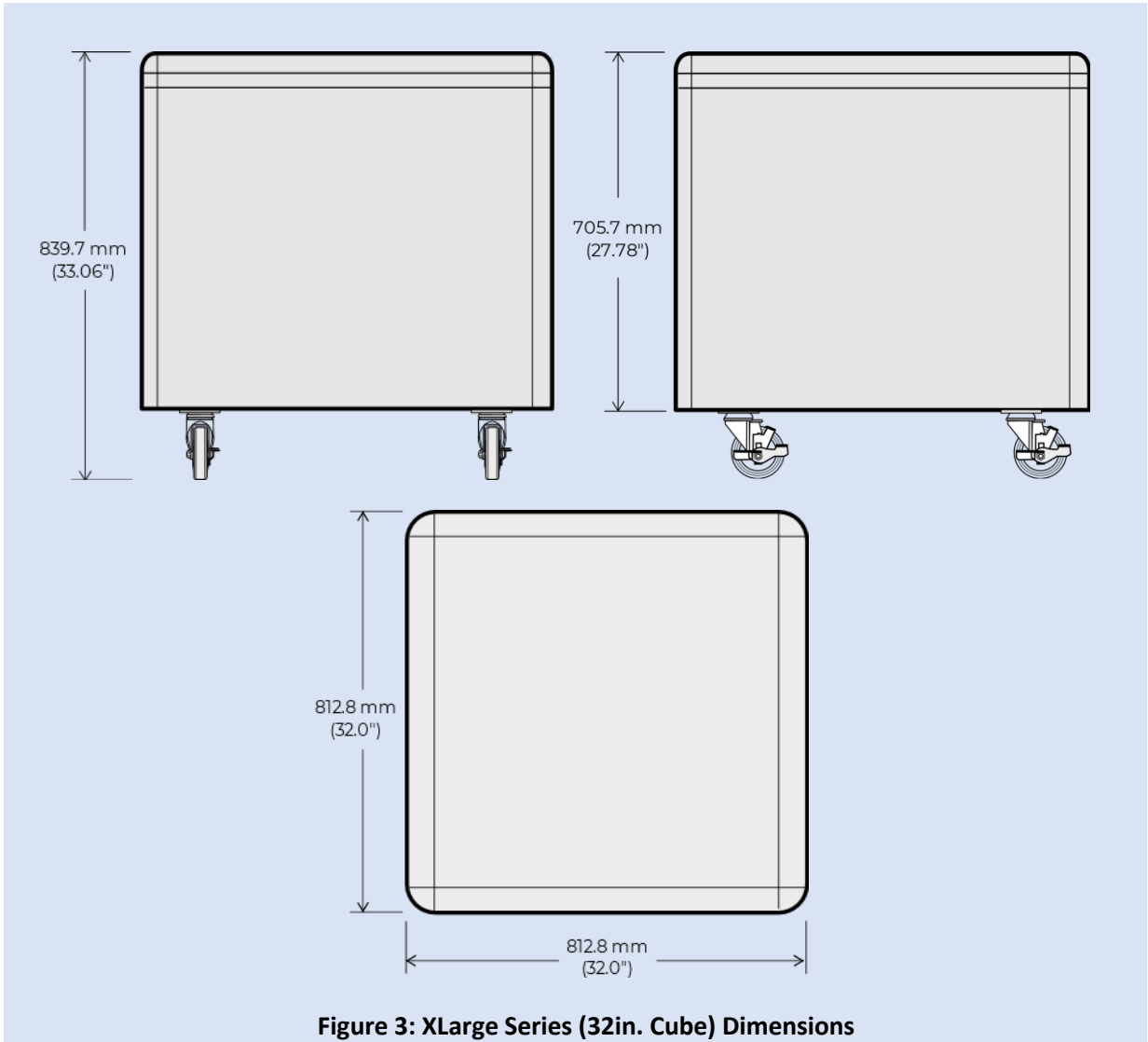

**Figure 3: XLarge Series (32in. Cube) Dimensions**

### **Dimensions**

## **1.5 CONSTRUCTION**

The VRP Series enclosures are constructed of Galvaneal Steel and finished with a light gray polyester powder coat and are intended for installation in a protected environment. The Enclosure base is 3.2 mm (0.125") thick and Enclosure sides and cover are 1.6 mm (0.063") thick.



**1.6 VRP ENCLOSURE TOP VIEW WITH COVERS REMOVED** -See Figures 4 and 5

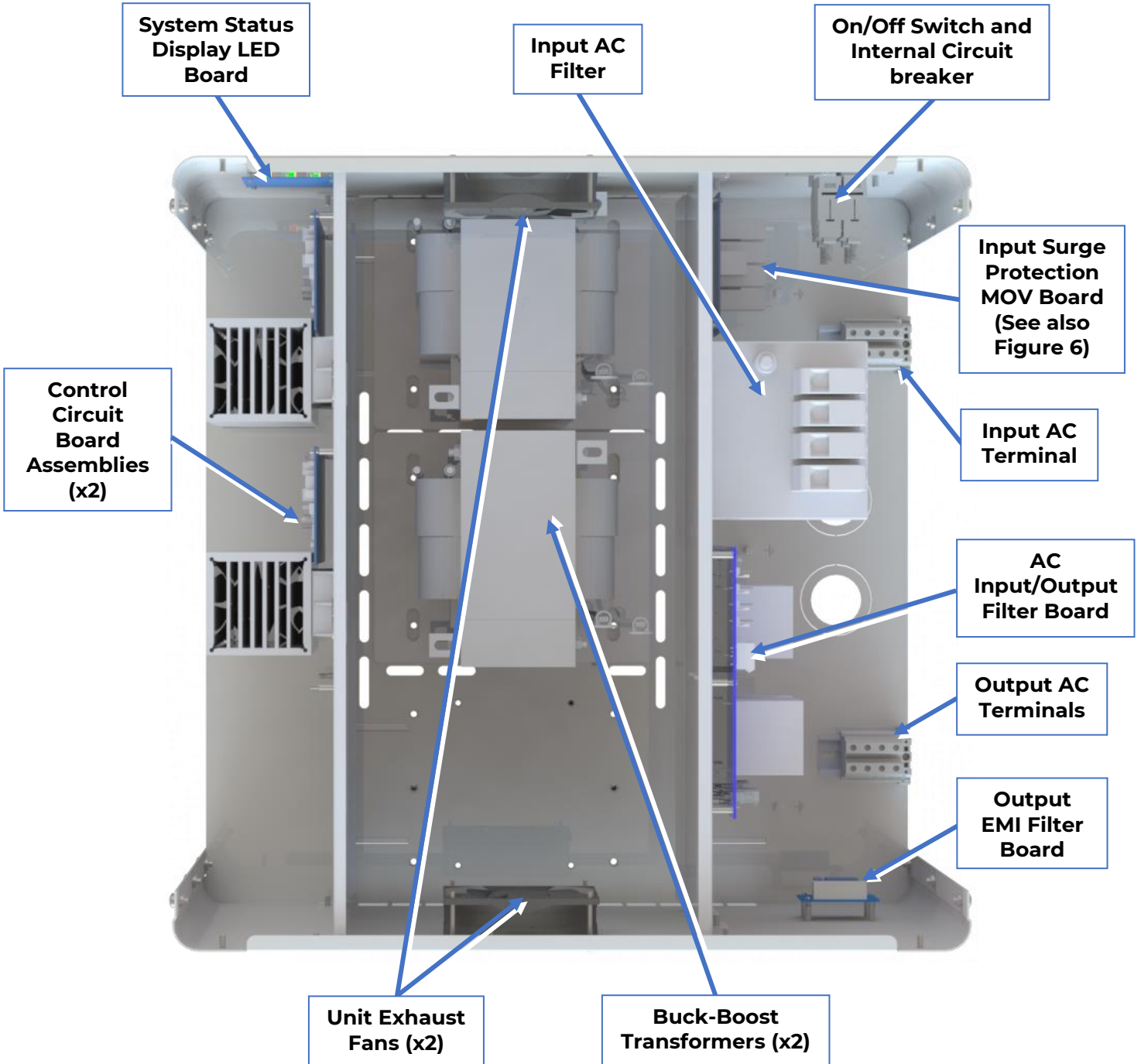

**Figure 4: Top View of Large Series (24in. Cube) with Covers Removed**

NOTE: Figure for reference only.

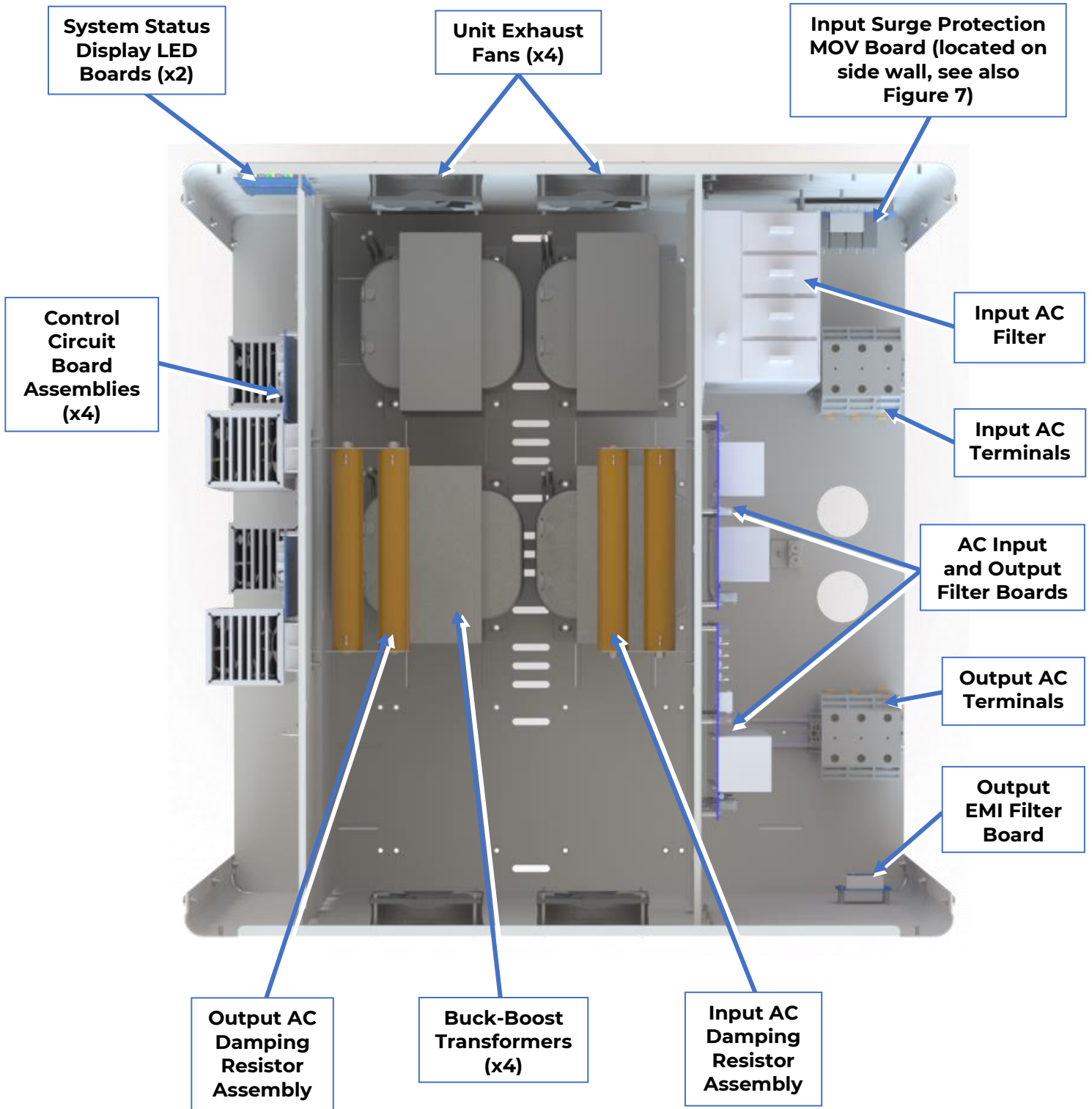

**Figure 5: Top View of XLarge Series (32in. Cube) with Covers Removed**

NOTE: Figure for reference only.

### 1.7 LARGE SERIES (24in. CUBE) HARDWIRE ACCESS

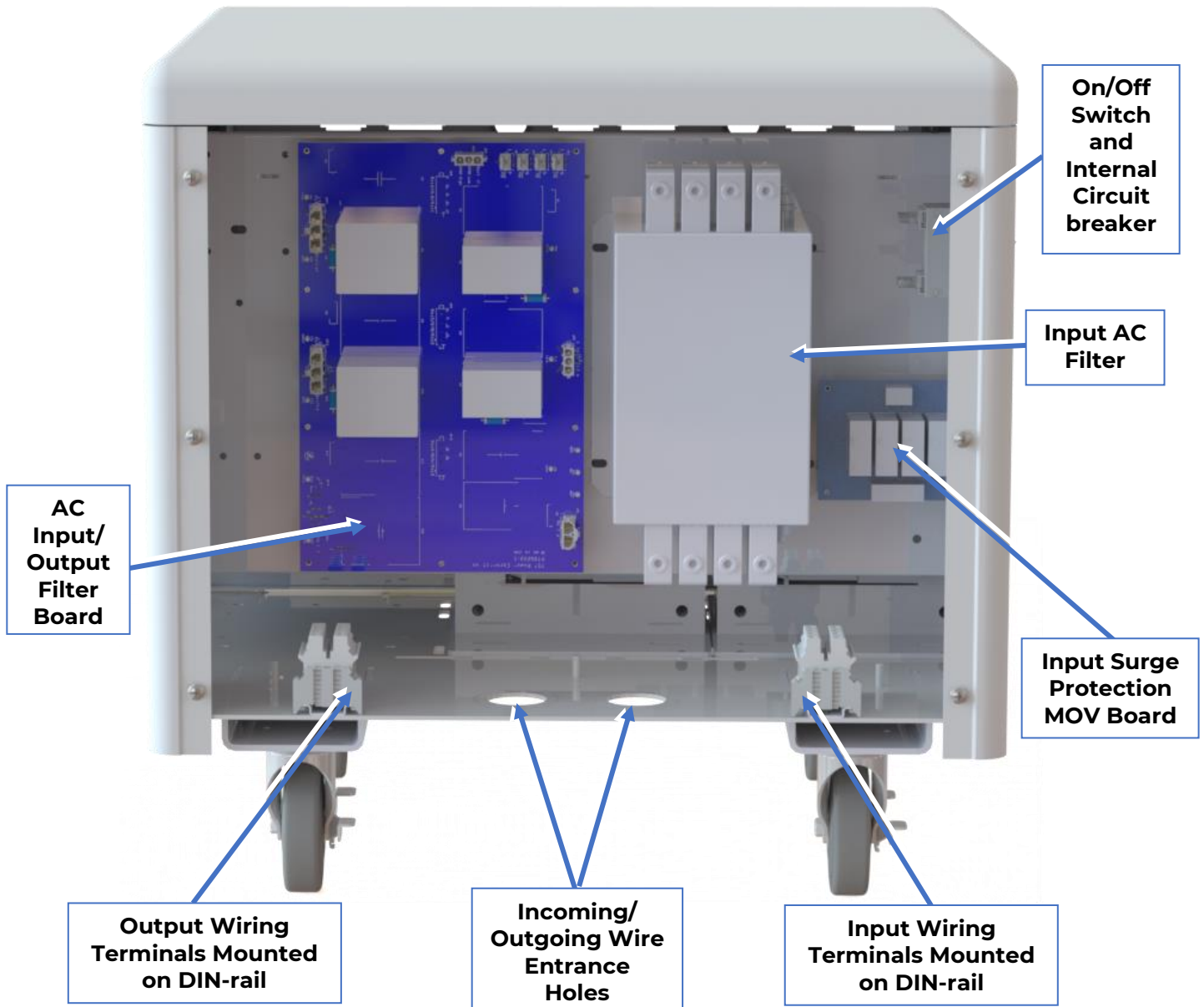

**Figure 6: Large Series (24in. Cube) VRP Shown With Wiring Access Cover Removed**

NOTE: Figure for reference only.

### 1.8 XLARGE SERIES (32in. CUBE) HARDWIRE ACCESS

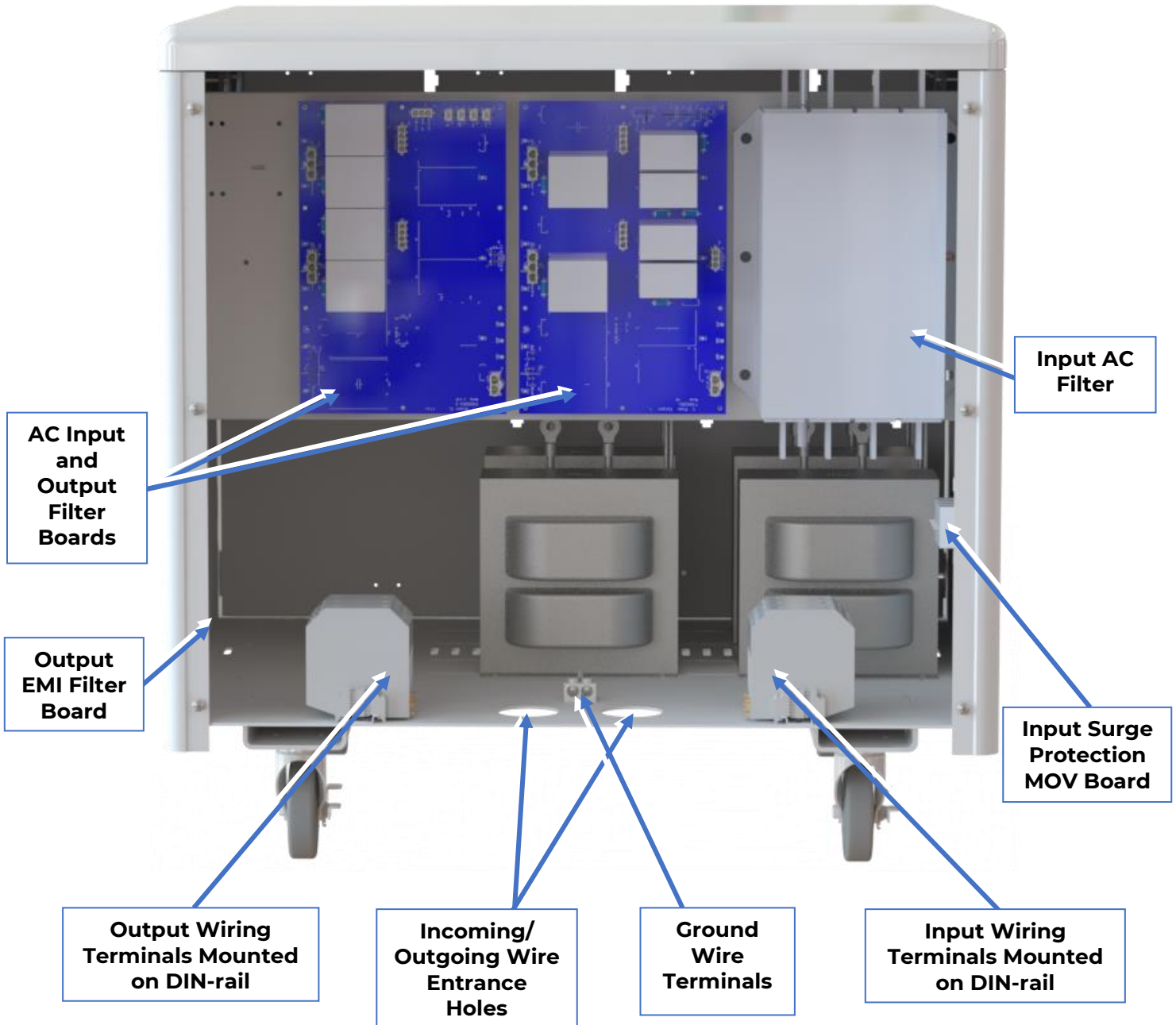
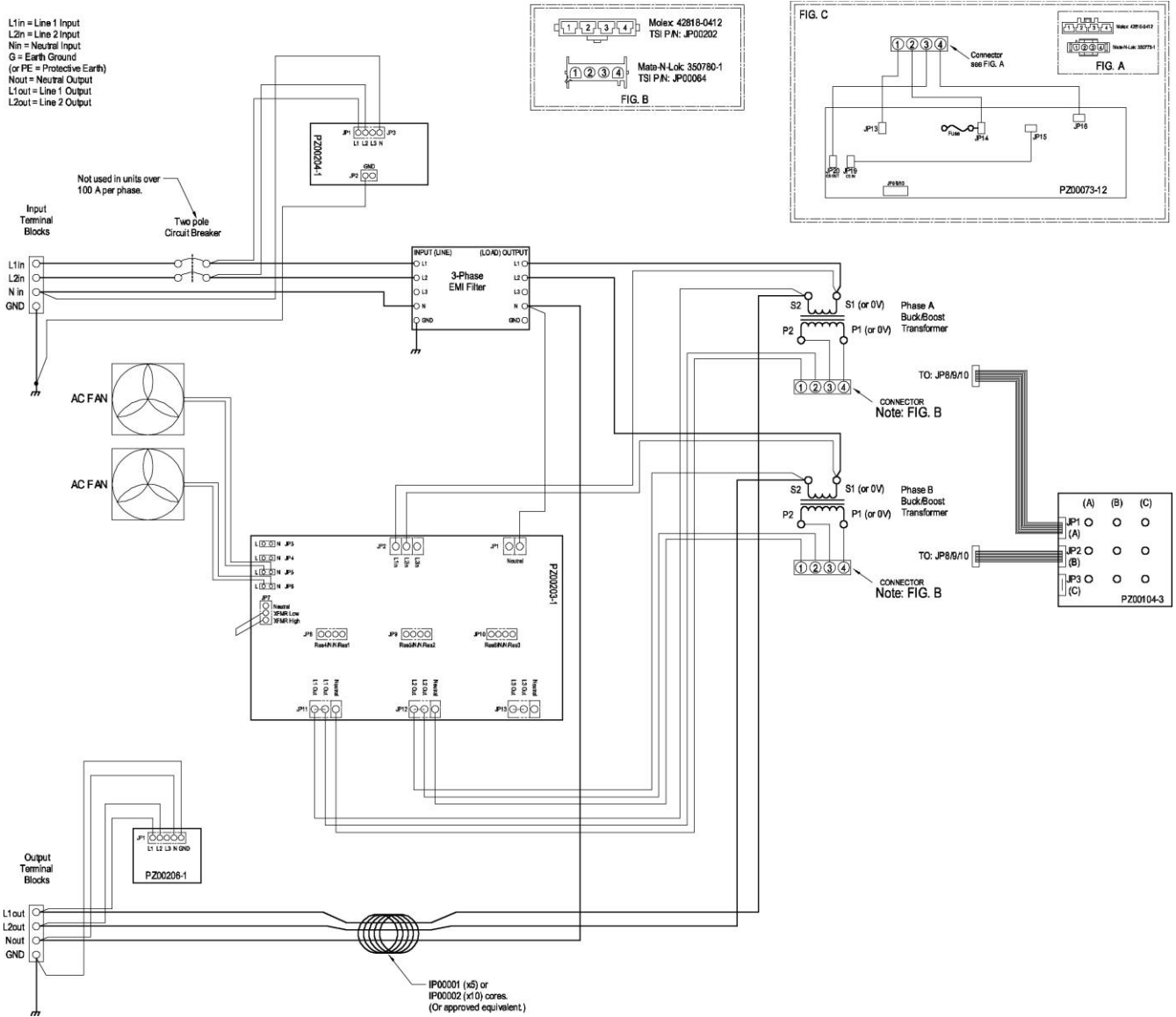

**Figure 7: XLarge Series (32in. Cube) VRP Shown With Wiring Access Cover Removed**

NOTE: Figure for reference only.

## 2 MAJOR COMPONENT/CIRCUIT DESCRIPTIONS

### 2.1 SPLIT PHASE VRP WIRING DIAGRAMS -See Figures 8 and 9



**Figure 8: Split Phase Large Series (24in. Cube) VRP Wiring Diagram**

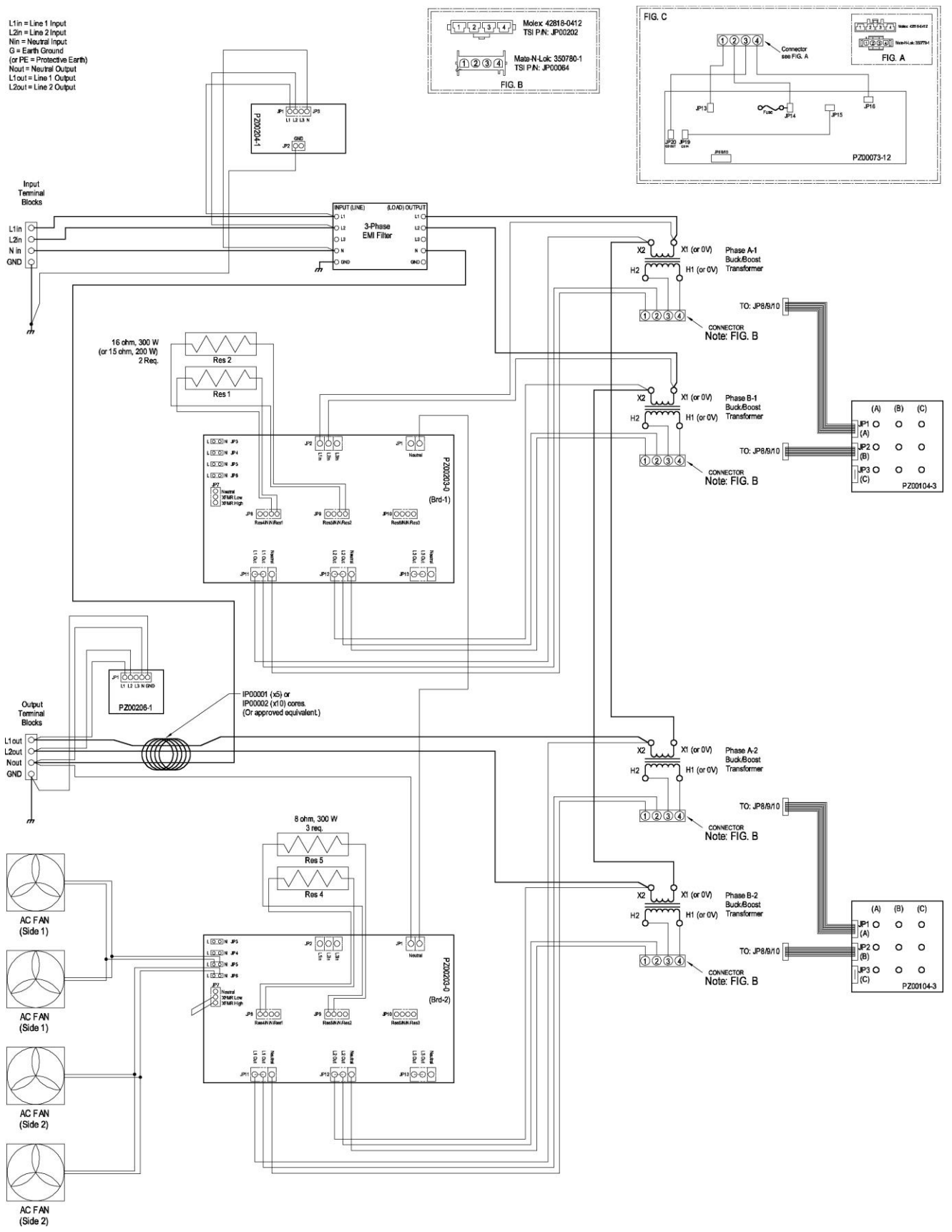

**Figure 9: Split Phase XLarge Series (32in. Cube) VRP Wiring Diagram**

## 2.2 BUCK-BOOST VOLTAGE REGULATION TRANSFORMERS -See Figure 10

These transformers supply current to the load through the secondary winding. The primary winding is used to impose the correction voltage.



**Figure 10: Buck-Boost Transformer for VRP-36.0k-100B Shown**

NOTE: Figure for reference only, actual component may vary in appearance.



### 2.3 CONTROL CIRCUIT BOARD ASSEMBLY -See Figure 11

The proprietary voltage regulation control board is powered by a DSP microcontroller. The Control Board's Firmware Version is located on a label affixed to the microcontroller (see Figure 11). It senses the incoming mains voltage and corrects the output continuously. It incorporates advanced algorithms to ensure the fastest possible response time while maintaining control loop stability.

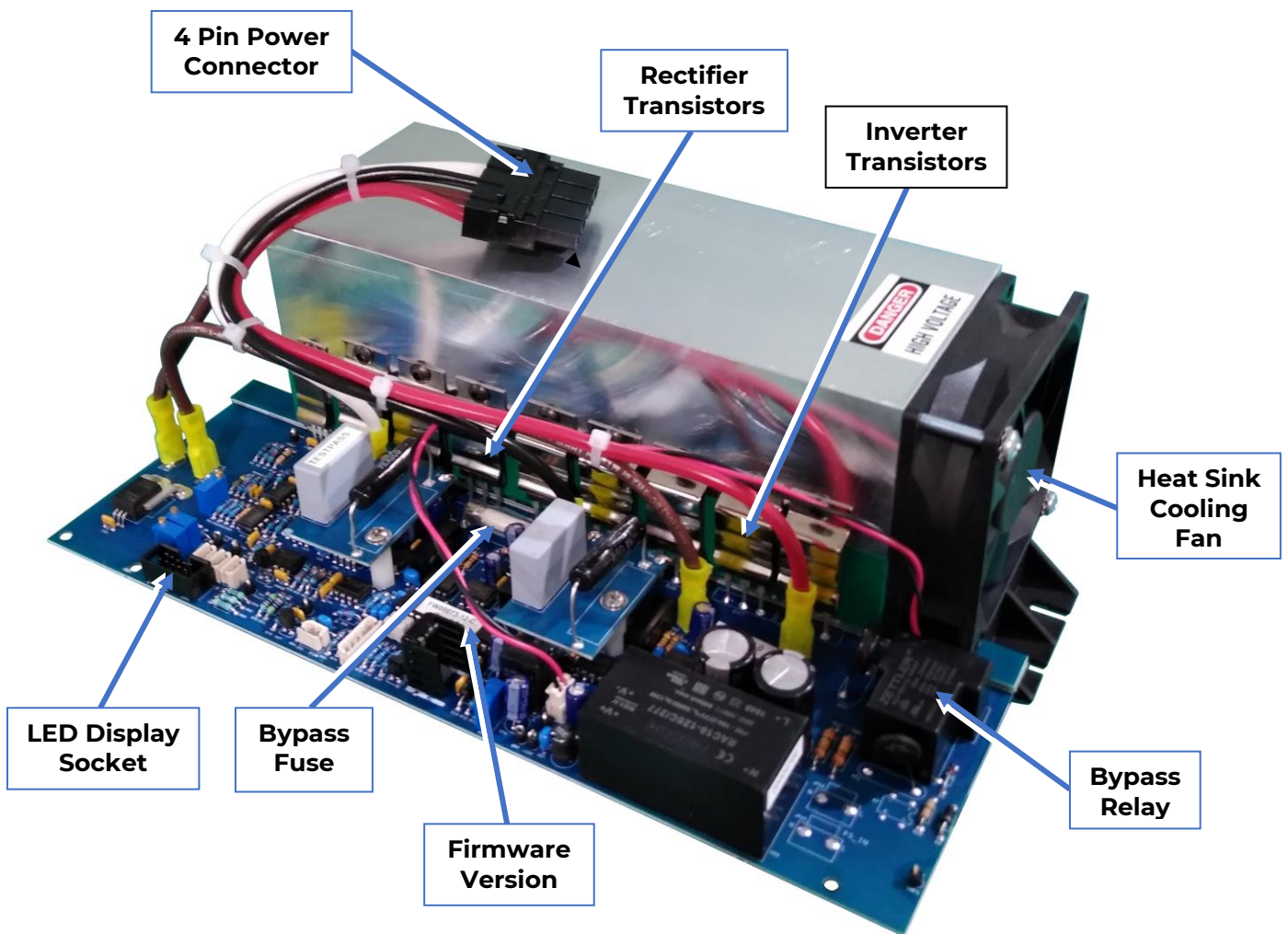

**Figure 11: PZ00073 Main Control Circuit Board Assembly Shown**

NOTE: Figure for reference only, actual component may vary in appearance



## 2.4 SURGE/FILTER CIRCUIT BOARD ASSEMBLIES -See Figures 12, 13, and 14

These circuit board assemblies provide output filtering to reduce voltage distortion.

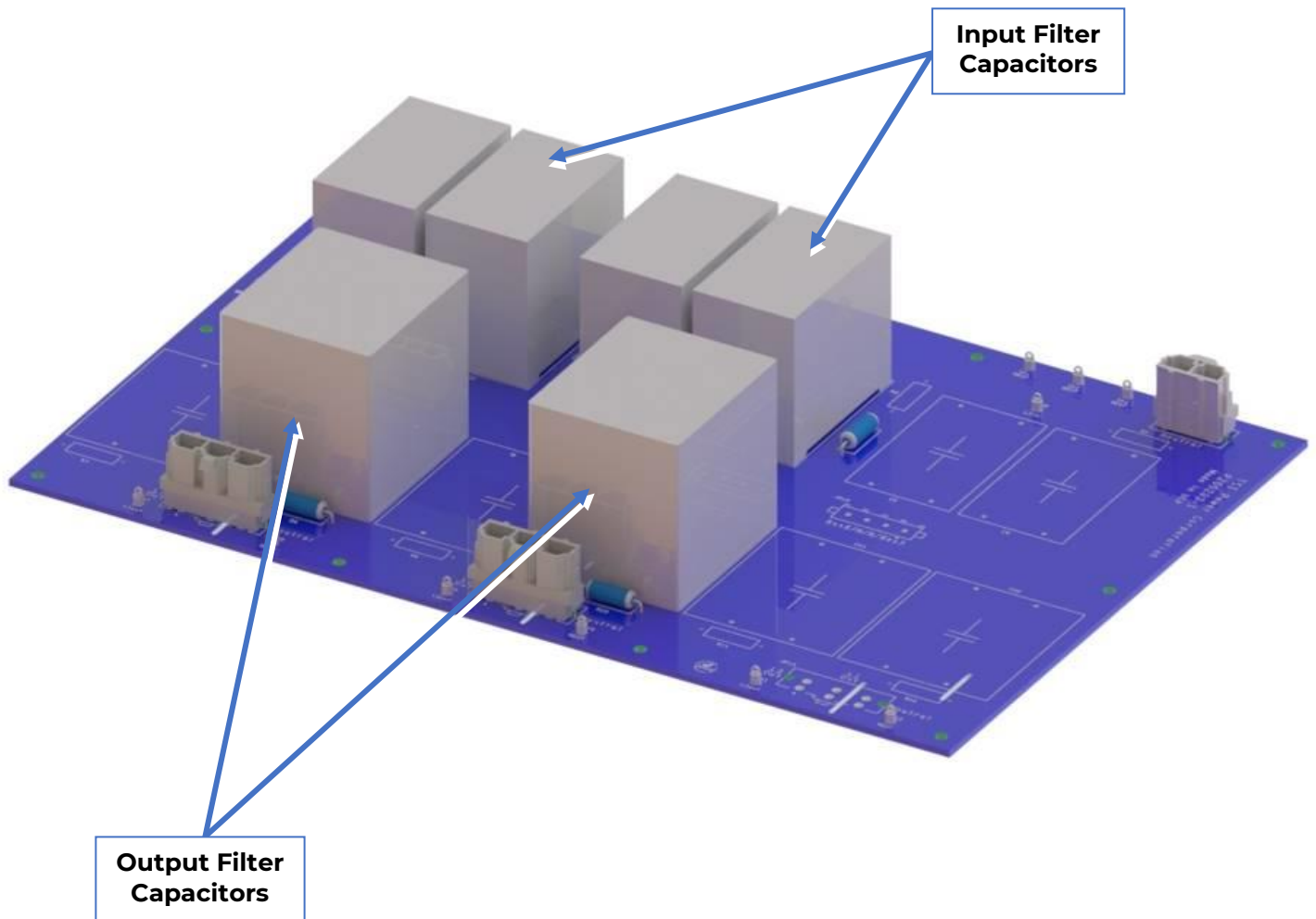

**Figure 12: PZ00203 Filter Circuit Board Assembly (PZ00203-1\_1-G shown)**

NOTE: Figure for reference only, actual component may vary in appearance

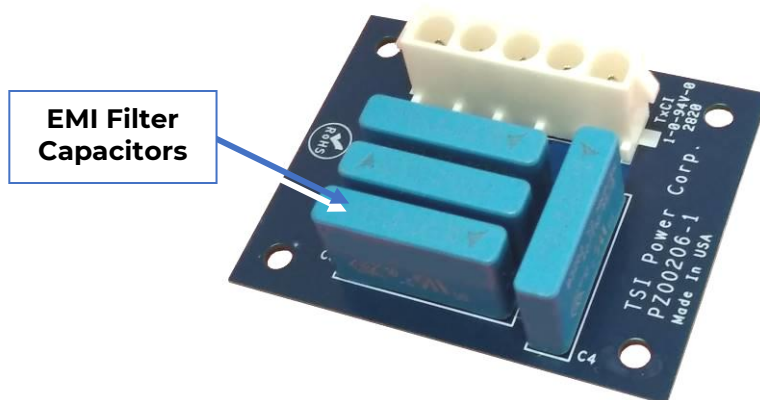

**Figure 13: PZ00206 EMI Filter Circuit Board Assembly**

This circuit board assembly provides Surge voltage diversion.

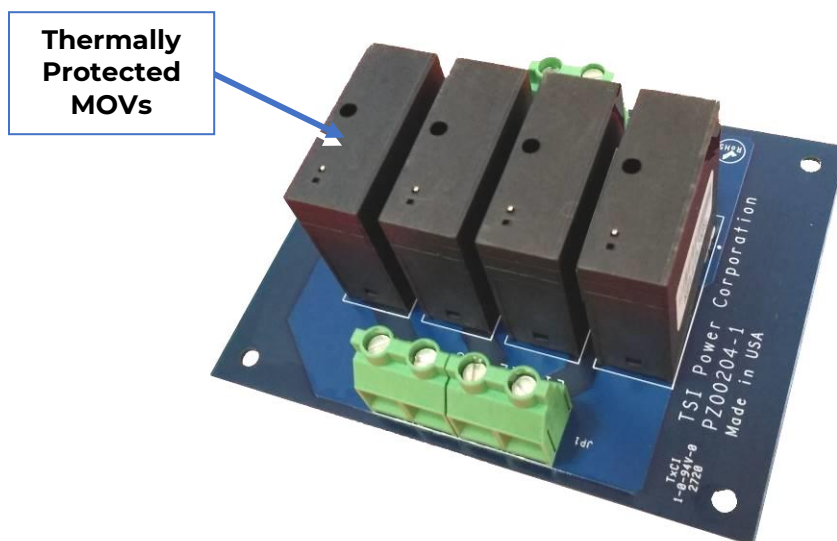
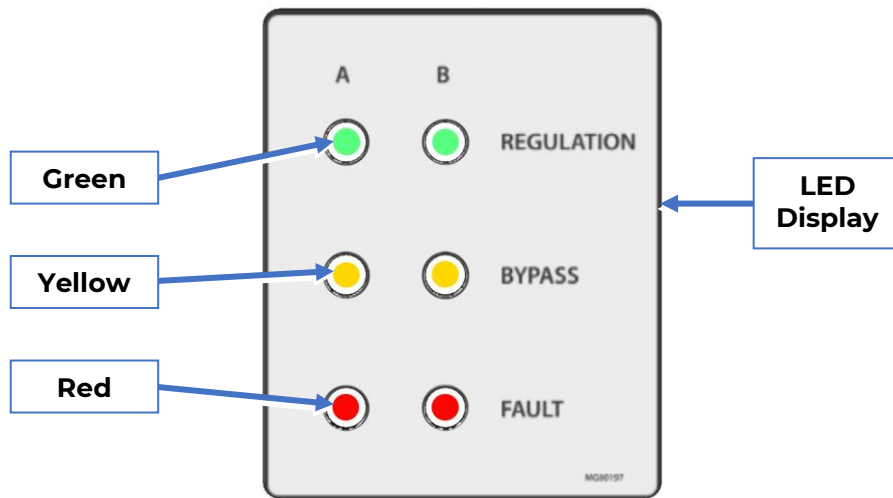

**Figure 14: PZ00204 Input Surge Circuit Board Assembly**

## 2.5 VRP STATUS INDICATORS – See Figures 15 and 16

These LEDs monitor the various conditions and display the following outputs:

1. Green LED indicates REGULATION mode.
2. Yellow LED indicates that system is in BYPASS mode.
3. Red LED indicates that the VRP is in electronic FAULT mode.



**Figure 15: Status Display LEDs**

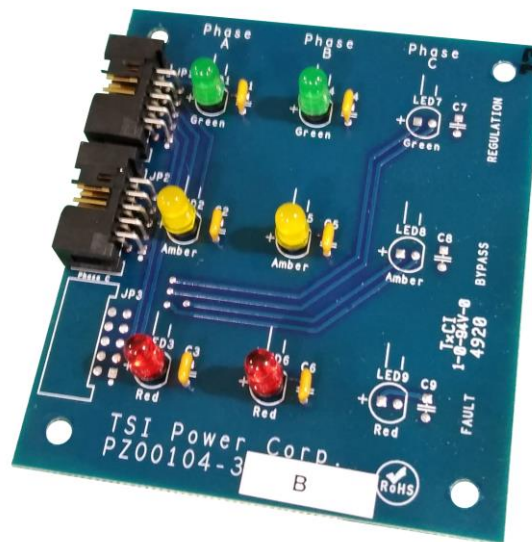

**Figure 16: Status Display LED Board -P/N PZ00104**

## 2.6 VRP INTERNAL CIRCUIT BREAKER -See Figure 17

The circuit breaker provides two functions; Note: Large Series (24in. Cube) only.

1. Over current protection
2. Unit on/off switch



**Figure 17: Two-Pole, Circuit Breaker, C-Series (left) and E-Series (right) Shown**

NOTE: Figure for reference only, actual component may vary in appearance.

## 2.7 VRP INPUT EMI FILTER -See Figures 18



**Figure 18: 40 A, Three-Phase EMI Filter -P/N EM00001 Shown**

NOTE: Figures for reference only, actual component may vary in appearance

**2.8 VRP UNIT EXHAUST FAN** -See Figure 19



**Figure 19: 120 mm, AC, Unit Exhaust Fan -P/N VF00009 or VF00052**

NOTE: Figures for reference only, actual component may vary in appearance.

**2.9 VRP HEAT SINK COOLING FAN** -See Figure 20



**Figure 20: 80 mm, DC, Heat Sink Cooling Fan -P/N VF00033**

NOTE: Figure for reference only, actual component may vary in appearance.

### 3 INSTALLATION

**IMPORTANT: ONLY QUALIFIED PERSONNEL SHOULD PERFORM THE INSTALLATION OF THIS PRODUCT.**

#### 3.1 SITE SELECTION & PREPARATION

- This product is intended for installation in “A PROTECTED ENVIRONMENT ONLY”.



**CAUTION: *The unit must be placed in a well - ventilated area to prevent risk of fire due to overheating. Ventilation slots must not be obstructed.***

- Select an area with enough space to provide sufficient clearance around the unit to provide unrestricted access.
- Make sure that nothing obstructs the cooling fan/fans.
- Once the unit is in place ensure that the casters are locked securely.
- Ensure that the closest distribution panel board has space and capacity for a circuit breaker rated for 1.25 x the maximum VRP input rating for the Large (24in. Cube) or 1 x the maximum VRP input rating for the XLarge (32in. Cube).

#### 3.2 REQUIRED TOOLS

- Set of standard hand tools
- Wire stripper
- DMM (digital voltmeter)

#### 3.3 UNPACKING & INSPECTION

3.3.1 The units are shipped in crates, normally one (1) unit per crate.

3.3.2 Inspect the shipping container for obvious damage.

3.3.3 If no visible damage is found, carefully open the crate making sure not to damage the unit, and remove the shipping foam and packing material.

3.3.4 Before the unit is removed from the crate, inspect for physical damage.

3.3.5 If no damage is found, remove the unit and again inspect for damage. If damage is found in either steps 3.3.2, 3.3.3, 3.3.4 or 3.3.5, do not accept the shipment and file a claim with the carrier. Contact TSI Power if a replacement unit needs to be purchased.

### 3.4 INSTALLING THE VRP

3.4.1 After the unit has been unpacked and no damage has been found, proceed with the installation as outlined below.

### 3.5 AC CONNECTIONS (HARDWIRE VERSIONS) Corded versions proceed to section 4

3.5.1 Make sure that the up-stream distribution panel circuit breaker is switched **OFF**.

3.5.2 Be sure to follow electric safety and installation codes in the country of use.

3.5.3 The VRP’s power entry is through two circular holes in the bottom of the unit (see Figure 6 or Figure 7). Remove the hardwire terminal access panel located at the side near the TSI logo and ratings labels (see Figure 1, page 5), save the hardware before proceeding.



**To prevent damage do not reverse input and output**

L<sub>1in</sub>, L<sub>2in</sub>, N<sub>in</sub> = INPUT

L<sub>1out</sub>, L<sub>2out</sub>, N<sub>out</sub> = OUTPUT



**When terminating wires, carefully insert each wire into the appropriate slot, taking care to ensure that all strands are inserted properly. Tighten the terminal screw using a slotted screwdriver for Large (24in Cube) VRPs or an appropriately sized Allen/hex wrench for XLarge (32in. Cube) VRPs, refer to Figure 21 for recommended torque. Perform a pull test to make sure each connection is secure. Do not apply excessive torque to make sure that the terminal screws are not damaged. Note that failure to follow these instructions can lead to malfunction or short circuit.**

RECOMMENDATIONS FOR VRP INSTALLATION								
Units with rated maximum:		External Branch Circuit Protection Rating	Minimum Wire Size (use stranded copper wire with a 105°C insulation system)		Torque For Wire Terminations, Screw Type Terminals		Wire Strip Length, Screw Type Terminals	
Input Current	Output Current		Power Conductors	Ground Conductors				
20.8 A	16.0 A	25 A	10 AWG (6mm <sup>2</sup> )	10 AWG (6mm <sup>2</sup> )	13.3 to 15.9 in-lb (1.5 to 1.8 Nm)		0.39" (10mm)	
31.3 A	24.0 A	40 A	8 AWG (10mm <sup>2</sup> )	10 AWG (6mm <sup>2</sup> )				
52.1 A	40.0 A	70 A	6 AWG (16mm <sup>2</sup> )	8 AWG (10mm <sup>2</sup> )				
83.3 A	64.0 A	100 A	3 AWG (27mm <sup>2</sup> )	8 AWG (10mm <sup>2</sup> )	28.3 to 32.7 in-lb (3.2 to 3.7 Nm)		0.63" (16mm)	
104 A	80.0 A	125 A	2 AWG (35mm <sup>2</sup> )	6 AWG (16mm <sup>2</sup> )				
196 A	150 A	200 A	3/0 AWG (85mm <sup>2</sup> )	6 AWG (16mm <sup>2</sup> )	Power Wires	Ground Wires	Power Wires	Ground Wires
227 A	181 A	225 A	4/0 AWG (120mm <sup>2</sup> )	4 AWG (25mm <sup>2</sup> )	18.4 to 22 ft.-lbs (25 to 30 Nm)	10 ft.-lbs (13.6 Nm)	1.56" (40mm)	0.63" (16mm)
255 A	208 A	250 A	300 kcmil	4 AWG (25mm <sup>2</sup> )	25 to 30 ft.-lbs (25 to 30 Nm)	10 ft.-lbs (13.6 Nm)	1.6" (40mm)	

**Figure 21: Branch Circuit Protection, Wire Size, Torque and Wire Strip Length Table**



3.5.4 Allow for sufficient wire length to reach the wiring terminals and leave enough slack to reduce the stress in the wires. Note: Three (3) wires plus ground are required for both input and output.

3.5.5 Strip insulation from the end of each of the Eight (8) wires and terminate them in the wiring terminals as follows.

- If lever type terminal blocks see Figure 22 or 23.
  - VRP with up to 40 A max output, strip wires from 13mm to 15mm.
  - Larger VRP strip wire as per instructed on top of terminal block.
- If screw type terminal blocks; strip wires and torque terminations per Figure 21.

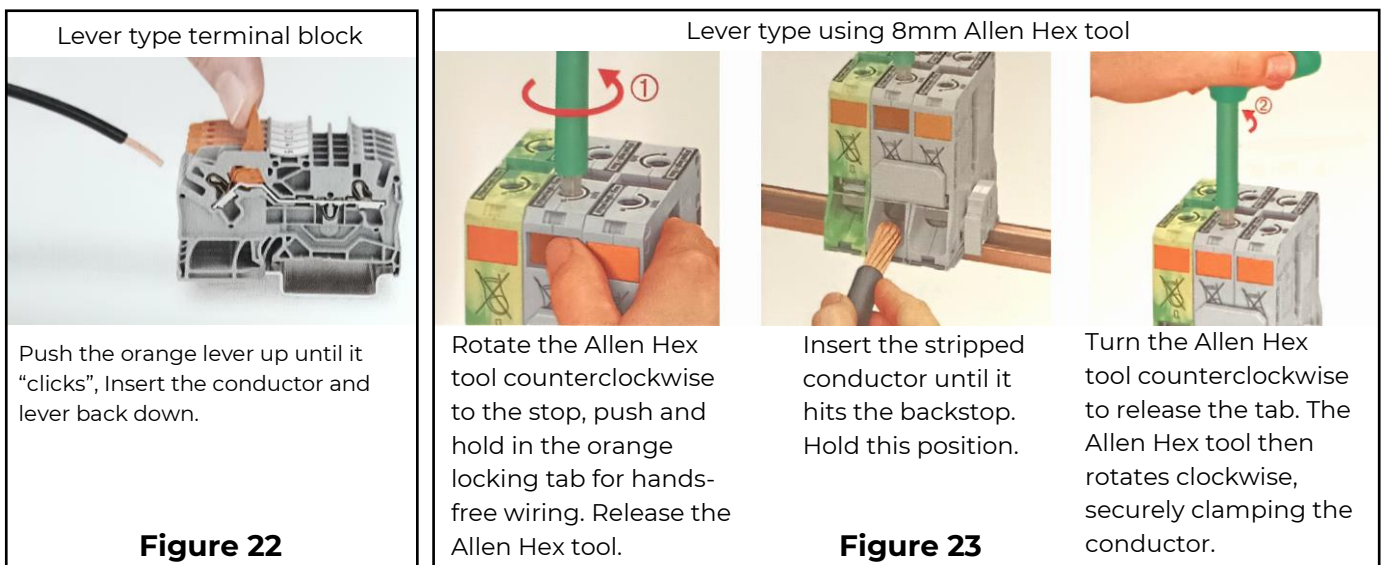

3.5.6 Terminate the incoming wires. The input terminals are on the right side of the unit (see Figure 6 or Figure 7). These terminals are marked as follows:

- **L1in** for Line 1 Input)
- **L2in** for Line 2 Input)
- **Nin** for Neutral Input
- **G** or  for input Earth Ground

3.5.7 Terminate the outgoing wires. The output terminals are on the left side of the unit (see Figure 6 or Figure 7). These terminals are marked as follows:

- **L1out** for Line 1 Output
- **L2out** for Line 2 Output
- **Nout** for Neutral Output
- **G** or  for output Earth Ground



## 4. POWERING UP THE VRP

 **CAUTION:** *External branch circuit protection is to be provided by the customer at 125% (100% for the XLarge 32in. Cube units) of the VRP's maximum input current rating as shown in Figure 21 (page 23) per the national electric code or per local electrical codes if outside of the United States.*

 **CAUTION:** *Before proceeding to the next step, make sure that the VRP's internal circuit breaker, if provided, is in the OFF position. For Hardwire units also make sure the ac input wires are de-energized before making connections.*

 *Before powering up the unit, make sure that the air Ventilation slots are free of obstruction to prevent overheating.*

 **CAUTION:** *Only people familiar with electricity should perform start-up of the VRP.*

 **CAUTION:** *Remove metallic watches and rings. Always wear safety glasses, insulated gloves and insulated shoes.*

### 4.1 CHECKING FOR PROPER INPUT VOLTAGE

4.1.1 Switch on the up-stream distribution panel circuit breaker.

4.1.2 Check for proper input voltage across Line to Neutral and Line to Line using an AC voltmeter.

4.1.3 The voltage must be within the input voltage range per the unit's ratings label.

4.1.4 If correct, switch off the up-stream distribution panel circuit breaker. For hardwire units, replace the hardwire terminal access panel using previously saved hardware.

**4.2 ENERGIZING THE VRP**—The following steps outline the procedures for putting the VRP into operation:

4.2.1 If using a VRP model with a Plug and Receptacle; plug the VRP into the up-stream power receptacle. Plug the load equipment (that needs to be powered and protected) into the VRP (if using a hardwired VRP model the input and output connections were performed during step 3.5).

4.2.2 Switch-on the up-stream distribution panel circuit breaker.

4.2.3 Turn-on the VRP internal circuit breaker if provided.

4.2.4 After the VRP is powered, the Yellow Bypass LED should flash briefly.

4.2.5 The Green Regulation LED will then illuminate and should stay on. At this time, the heat sink cooling fan should be on, this is NORMAL. The unit's AC cooling fans should also be on. (The Bypass LED should be off.)

CONSULT VRP TROUBLE-SHOOTING PROCEDURE IF THE GREEN REGULATION LED IS NOT LIT AND/OR THE RED FAULT LED ILLUMINATES.

4.2.6 Check for proper output voltage across Line to Neutral and Line to Line using an AC voltmeter. Output voltage should be  $\pm 3\%$  of the nominal voltage per the unit's ratings label.

4.2.7 Verify that the load equipment is operating properly.

4.2.8 THE SYSTEM IS NOW IN OPERATION.

## **5. MAINTAINING THE VRP**

To make sure that the unit is functioning properly and safely, check the following periodically or at least once a year:

### **5.1 VRP OPERATION**

5.1.1 Verify that the Green Regulation LED is illuminated.

5.1.2 Check if the unit appears hot to the touch as this indicates overload or fan failure.

5.1.3 Check and verify operation of the heat sink fans and unit exhaust fans.

### **5.2 ENCLOSURE INTEGRITY**

5.2.1 Check the air intake and exhaust for dust and debris, remove as required.

5.2.2 Check for moisture and water accumulation and remove as necessary.

5.2.3 Check to make sure casters are locked.

## **6. TROUBLESHOOTING & COMPONENT REPLACEMENT**

### **6.1 VISUAL STATUS INDICATORS**

6.1.1 The Regulation LED (green LED) on the enclosure chassis must be ON.

6.1.2 If the Regulation LED is not on, it could mean any of the following:

- There is no AC power present,
- Internal circuit breaker (if provided) is in the off position,
- Supply circuit breaker is in the off position,
- Bypass Fuse (see figure 11) on PCB assembly is blown thus indicating failure of power switching transistors.

- 6.1.3 If the Bypass LED (yellow LED) is ON (flashing), the internal bypass is activated. This state indicates that the VRP is either overloaded or is receiving an insufficient input voltage.
- 6.1.4 If the Fault LED (red LED) is ON (flashing), the VRP is in the electronic fault mode. The cause could be any of the following:
- Component overheating the heatsink,
  - Out of range frequency,
  - Failed component or circuit that prevents normal operation.

After orderly shutdown of the equipment that is connected, turn off the VRP's input circuit breaker (if provided) or the upstream circuit breaker. Restart the VRP by switching the circuit breaker back on. The Fault LED will turn OFF if the fault is temporary. If it does not, replace the Control Circuit Board Assembly.

## **6.2 DECOMMISSIONING THE VRP & INSPECTING FOR DAMAGE**

6.2.1 Follow the steps below to decommission the VRP:

- Switch off the internal circuit breaker, if provided.
- Switch off the up-stream distribution panel circuit breaker.
- Remove the case cover/covers.

6.2.2 Use a light to perform the inspection as follows:

- Check continuity of the Control Board Assembly Bypass Fuse/Fuses.
- Look for any obvious burn marks.
- Look for any damaged, cracked or discolored parts which might provide a clue as to what might have caused the unit failure.
- If no defect is found following inspection, you may decide to ship the entire unit back to TSI Power for factory repair or a replacement.

## **7. REPAIRS, SERVICE & SPARE PARTS**

### **7.1 REPAIRING VRP**

The VRP units should only be repaired by persons with a general knowledge of electronics and electrical safety procedures. Others should contact TSI Power Corp. for an RMA (Return Material Authorization). The TSI Power representative will ask a few simple questions and issue an RMA if factory repair is required.

## **7.2 REPAIRING VRP IN THE FIELD**

**7.2.1** The VRP is designed to facilitate quick replacement of modules in the field. Therefore, trouble-shooting procedures described in this manual are limited to identification of faulty modules that can be replaced by persons with a general knowledge of electronics.

**7.2.2** The main Control Circuit Board Assembly used in the VRP is not designed to be repaired in the field as it utilizes a microcontroller and programmable logic device.

**7.2.3** Spare parts can be ordered from TSI directly. However, contact TSI Power prior to ordering to ensure that the proper parts are specified for the specific VRP model.

### **Note 1: For customers with a large number of VRP units –**

Since board exchange is the quickest way to repair a failed VRP unit, TSI Power recommends that customers keep at least 3% (one board set for every 30 VRP units) in spare main boards in order to minimize VRP downtimes while failed boards are being repaired at TSI Power.

### **Note 2: For international customers with a large number of VRP units –**

Keeping about 5% (one board set for every 20 VRP units) in spare boards is highly recommended to minimize VRP repair time. Also, shipping costs (per each repaired board) can be reduced dramatically by always shipping a group of three or more boards in the same box, as the cost of international air shipment can be very high.

### **7.2.4 Returning defective modules for repair or replacement**

- Contact TSI via telephone or e-mail to obtain a Return Material Authorization number (RMA).
- Make sure that returned parts are properly protected and packed in suitable shipping box, especially when sending parts via United Parcel Service.
- Mark shipping box with RMA number using indelible marker pen.
- TSI recommends that DHL be used for shipments originating outside the USA and FedEx for US domestic shipments. Do not use UPS if possible.
- Upon receiving the part, TSI will determine if it is covered by warranty, warranty repair or replacement is performed without charge. TSI will quote repair costs for out-of-warranty parts prior to starting any repair work. If repair is not cost effective, TSI will quote the cost of a replacement part.
- Shipping costs, duty and brokerage costs are the responsibility of the customer.

### 7.3 SPARE PARTS

The table below shows replaceable parts that can be ordered from TSI Power if necessary.

\* Contact TSI for part number.

Voltage	Unit Part Number	Buck/Boost Transformer	Control Circuit Board Assembly	Filter Circuit Board Assembly	Surge Circuit Board Assembly	EMI Circuit Board Assembly	LED Circuit Board Assembly	Input Filter	Circuit Breaker *	Unit Exhaust Fan	Heat Sink Cooling Fan
120/240 V Split Phase	VRP-3.8k-1XXX	TP00172T	PZ00073-12-A	PZ00203-1-E	PZ00204-1-C	PZ00206-1	PZ00104-3-B	EM00001	2x 20 A	VF00009	VF00033
	VRP-5.8k-1XXX	TP00215T	PZ00073-12-A	PZ00203-1-E	PZ00204-1-C	PZ00206-1	PZ00104-3-B	EM00001	2x 30 A	VF00009	VF00033
	VRP-9.6k-1XXX	TP00156	PZ00073-12-A	PZ00203-1-E	PZ00204-1-C	PZ00206-1	PZ00104-3-B	EM00007	2x 50 A	VF00009	VF00033
	VRP-15.4k-1XXX	TP00207	PZ00073-12-E	PZ00203-1-E	PZ00204-1-C	PZ00206-1	PZ00104-3-B	EM00007	2x 80 A	VF00009	VF00033
	VRP-19.2k-1XXX	TP00273T	PZ00073-12-E	PZ00203-1-E	PZ00204-1-C	PZ00206-1	PZ00104-3-B	EM00002	2x 100 A	VF00052	VF00033
	VRP-36.0k-1XXX	TP00221 (2 per phase)	PZ00073-12-E (2 per phase)	PZ00203-1-G / PZ00203-1-H	PZ00204-1-C	PZ00206-1	PZ00104-3-B	EM00005	None	VF00052	VF00033
	VRP-43.3k-1XXX	TP00301 (2 per phase)	PZ00073-12-E (2 per phase)	PZ00203-1-G / PZ00203-1-H	PZ00204-1-C	PZ00206-1	PZ00104-3-B	EM00005	None	VF00052	VF00033
	VRP-49.9k-1XXX	TP00302 (2 per phase)	PZ00073-12-E (2 per phase)	PZ00203-1-G / PZ00203-1-H	PZ00204-1-C	PZ00206-1	PZ00104-3-B	EM00005	None	VF00052	VF00033

### 7.4 REPLACEMENT OF HEAT SINK COOLING FAN

**7.4.1** Verify that the fan is operating properly, check for airflow through heat sink on main control board and replace the fan if there is any doubt that it is operating properly.



**Do not ignore a poorly operating fan as serious damage to power switching transistors can occur.**

**7.4.2** Contact TSI Power for a replacement heat sink fan (TSI part number: VF00033).

**7.4.3** Follow these steps to replace:



**WARNING: Make sure unit is de-energized before beginning fan replacement.**

- Using a Phillips screw driver, remove all the screws and washers that hold the fan to the heat sink and set aside.
- Disconnect fan connector from JP12 FAN header on board.
- Install new fan with the airflow towards the heat sink. Check that fan spins freely after installation.

### 7.5 REPLACEMENT OF MAIN CONTROL BOARD ASSEMBLY

**7.5.1** Contact TSI Power for a replacement main control board assembly (PZ00073-12).

**7.5.2** Follows these steps to replace:

- When a new spare PCB board assembly is received, examine it to make sure there is no damage resulting from mishandling during shipment.

- Take care to assure that the board is not damaged by static electricity by using a properly grounded wrist strap.



**WARNING: Make sure unit is de-energized before beginning main control board replacement.**

- Disconnect the LED Display Ribbon Connector and 4 Pin Power Connector of the failed Control Board Assembly.
- Remove the failed Control Board Assembly. Four (4) fasteners hold each assembly, two on either end of large heat sink.
- Install the new Control Board Assembly using the four (4) removed fasteners.
- Connect the LED Display Ribbon Connector and 4 Pin Power Connector to the new Control Board Assembly, (*Note: Make sure the connectors are secure*).
- Energize (power up) the VRP (refer to Section 4 **POWERING UP THE VRP**).

## 7.6 REPLACEMENT OF UNIT EXHAUST FAN

**7.6.1** Verify that the fan is operating properly, check for airflow through the fan and replace the fan if there is any doubt that it is operating properly.



**Do not ignore a poorly operating unit exhaust fan as serious damage to components can occur from overheating.**

**7.6.2** Contact TSI Power for a replacement unit exhaust fan.

**7.6.3** Follow these steps to replace:



**WARNING: Make sure unit is de-energized before beginning fan replacement.**

- Take note of the direction of the fan's airflow (note the arrow shown on the fan).
- Disconnect fan electrically from the unit by disconnecting the QDTs (Quick Disconnect Terminals).
- Using a Phillips screw driver, remove all the screws and washers that hold the fan to the unit and set aside.
- Install new fan with the airflow the same direction as determined in the first step above. Check that fan spins freely after installation.

## 8. CONTACT INFORMATION

### 8.1 TSI POWER CONTACT INFORMATION

**TSI Power Corporation  
1103 West Pierce Avenue  
Antigo, WI 54409, USA  
Toll-Free 800 874 3160 (for USA & Canada only)  
+1 715 623 0636  
URL: [www.tsipower.com](http://www.tsipower.com) E-mail: [sales@tsipower.com](mailto:sales@tsipower.com)**