



Pure sine wave

Wide temperature batteries

Voltage regulation

Outdoor XUPs  
model

## 1000A

1000 VA  
700 watts  
120 vac  
25 min @ 700W  
1 hour @ 350W  
-20° to +60°C;  
-40° to +60°C  
with optional  
battery heater

## 1000B

1000 VA  
700 watts  
120 vac  
50 min @ 700W  
2 hrs @ 350W  
-20° to +60°C;  
-40° to +60°C  
with optional  
battery heater

## Outdoor UPS with voltage regulation

The TSi Power Outdoor XUPs-1000A/B units are constructed with extreme wide temperature batteries, and are housed in a weather protected IP44(NEMA-3R) enclosure. These offer line-interactive automatic voltage regulation, over/under-voltage protection, surge protection with heavy duty noise filtering, communications capability and optional extended battery backup.

### Key Outdoor XUPs benefits

This rugged UPS design, with microprocessor-controlled 20 kHz sine wave inverter and optional conformal coated boards, reduces the number of solid-state devices required for power conversion and is suitable for use in severe outdoor environments.

Outdoor XUPs extreme/wide temperature batteries allow operation of the UPS system over an ambient temperature range of -20° to +60°C (-4° to +140°F); -40° to +60°C (-40° to +140°F) with optional battery heater. Built-in automatic voltage regulation enables a wide input voltage window within which power is delivered without having to drain or exercise the batteries, thereby ensuring long battery life. A fan exhausts hot air to protect batteries and electronics.

Battery run-times for the OutdoorXUPs-1000A are approximately 25 minutes at 700 watts load, and 1 hour with a 350 watts load; for the OutdoorXUPs-1000B, approximately 50 minutes at 700 watts load, and 2 hours at 350 watts.

### How the Outdoor XUPs works

The Outdoor XUPs Series UPS provides automatic voltage regulation with surge protection and noise filtering, as well as overvoltage protection with a threshold of 140 vac, and undervoltage protection with a threshold of 95 vac. Upon a brownout, overvoltage, or loss of power, the XUPs will transfer to battery power in less than 4 milliseconds, enabling uninterrupted operation of computer, telecom, surveillance, signaling or other systems.

LEDs provide visual assessment of UPS status. By unlatching, the front door swings open; inside the cabinet is an array of LED status indicators and a power on/off control switch.



Note: shown with optional liquid-tight cable glands

### Typical applications

This heavy duty outdoor UPS system is ideal for protection of WiFi/GSM/CDMA/satellite base stations, wireless communications/perimeter surveillance and security/gate control systems, LED traffic light/roadway display systems and industrial remote terminal units (RTUs).

### Key Outdoor XUPs features

- Cabinet can be pedestal (ground), pole, or wall mounted
- Full weather outdoor protection IP44(NEMA-3R) metal cabinet
- Pure sine wave output
- Over/under-voltage protection
- Remote power on/off (optional)
- Wide temperature batteries
- Heavy-duty surge protection and noise filtering
- Automatic voltage regulation
- Comprehensive array of status bargraphs for voltage, load and battery levels
- Two year warranty on electronics, parts and labor; manufacturer's warranty on batteries



**TSi Power Corporation**  
1103 West Pierce Ave  
Antigo, WI 54409 USA  
800 874 3160 (USA only)  
Phone +1 715 623 0636  
Fax +1 715 623 2426  
sales@tsipower.com  
www.tsipower.com  
Copyright © 2010 TSi

# Outdoor XUPs



Outdoor line-interactive UPS with automatic voltage regulation and extreme/wide temperature batteries



Ac input and UPS output cable entry shown via two optional 25mm (1") liquid-tight cable glands

TSi's ongoing product improvement process makes specifications subject to change. Other companies product names herein are for identification purposes only, and may be trademarks of their respective companies.



**TSi Power Corporation**  
1103 West Pierce Ave  
Antigo, WI 54409 USA  
800 874 3160 (USA only)  
Phone +1 715 623 0636  
Fax +1 715 623 2426  
sales@tsipower.com  
www.tsipower.com  
Copyright © 2010 TSi

Specification	OutdoorXUPs - 1000A	OutdoorXUPs - 1000B
<b>Electrical</b>		
Capacity in VA (watts)	1000VA (700W)	
UPS topology	High efficiency line-interactive with 20 kHz PWM sine wave inverter	
<b>Input</b>		
Nominal voltage	120 volts ac	
Input current	8.3 amperes maximum @ 120 vac	
Operating voltage	95–140 vac without using batteries	
Operating frequency	47–63 Hz	
<b>Output</b>		
Nominal voltage	120 volts ac	
Voltage regulation	115 vac +/- 8% upon changes in line or load	
Crest ratio	3:1	
Output waveform	Pure sine wave, less than 3% THD with linear load	
Power efficiency	97%, under full load conditions	
Power on/off switch	On/off rocker style power switch	
Transfer time	<4 milliseconds	
Batteries	32 ampere hours, 24 vdc	64 ampere hours, 24 vdc Wide temperature sealed gel-cells -20° to +60°C (-4° to +140°F); -40° to +60°C (-40° to +140°F) with optional battery heater.
Battery backup time	25 minutes @ 700 watts load. 1 hour @ 350 watts load.	50 minutes @ 700 watts load. 2 hours @ 350 watts load.
Recharge time	8 hours to 90% capacity after full discharge.	16 hours to 90% capacity after full discharge.
SNMP interface for UPS monitoring and automatic shutdown configuration (optional)	Using an external SNMP adapter, the RS-232 signals (from the DB-9 female connector) from the UPS can be converted to 10M/100M fast Ethernet signals (and RJ-45 connection) for external UPS monitoring/configuration capability using Telnet, web browsers, or NMS (for TCP/IP, UDP, SNMP, Telnet, SNT, PPP, HTTP & SMTP protocols).	
Surge let-through voltages	Test pulse injection: Line-Neutral: Line-Ground: and Neutral-Ground. Combination Wave: L-N: 450V, L-G: 300V, N-G: 300V	
Status indicators	5 LED load level indicator: 0 to 100% of rated load. 5 LED battery charge level indicator from 0 to 100% of rated charge. 3 LED indicators for: in boost, buck or normal mode. 3 LED indicators for: inverter on/off, battery fault, and overload.	
Input/output connections	3 position terminal blocks provided for 3 x 1.5mm <sup>2</sup> (16AWG) connections via 12mm (1/2") diameter holes.	
<b>Physical</b>		
Dimensions	610mm (24") wide x 305mm (12") deep x 610mm (24") high	
Weights	50 kg (110 lbs)	73 kg (160 lbs)
Steel cabinet	Full weather IP44 (NEMA-3R) outdoor design.	
Mounting options	Bolting or banding mountable to monopole via optional 'H' style bracket (steel mounting bands not included), pedestal (ground) with optional bottom mounted u-channel, or wall mountable via four wall mounting 'feet' which are included standard.	
<b>Environmental</b>		
Operating temperature, battery heater option and cooling method	-20° to +60°C (-4° to +140°F) ambient air temperature. -40° to +60°C (-40° to +140°F) with optional battery heater. Thermostat controlled exhaust fan.	
Moisture protection	Conformal coating of electronic boards for moisture resistance to protect against high humidity environments.	
<b>Warranty</b>		
Warranty	2 year limited warranty, parts & labor; manufacturer's battery warranty.	



Outdoor  
XUPs



optional bandable or  
bolttable monopole  
mounting brackets



## OutdoorXUPs-1000A/B system architecture

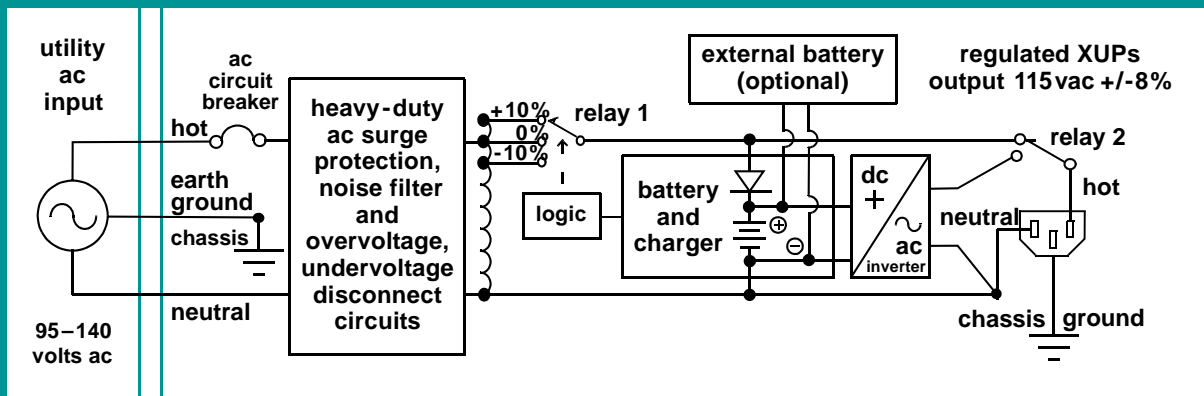

## OutdoorXUPs-1000A/B at a glance

Heavy-duty outdoor UPS with line-interactive automatic voltage regulation and extreme/wide temperature batteries

- Wide ambient temperature range sealed gel-cell batteries:  
-20° to +60°C (-4° to +140°F); or  
-40° to +60°C (-40° to +140°F)  
with optional thermostat controlled battery heater
- 24 vdc battery bus
- **25 minutes @ 700 watts**, or  
1 hour @ 350 watts with the  
**OutdoorXUPs-1000A**
- **50 minutes @ 700 watts**, or  
2 hours @ 350 watts with  
**the OutdoorXUPs-1000B**
- 115 vac +/- 8% output  
from 95–140 vac input  
without going to batteries
- Weather protected  
IP44/NEMA-3R  
painted metal cabinet
- SNMP compatible (optional)
- Less than 4ms transfer time
- Microprocessor-controlled  
20 kHz PWM sine wave inverter
- Thermostat controlled  
fan is included



**TSi Power Corporation**  
1103 West Pierce Ave  
Antigo, WI 54409 USA  
800 874 3160 (USA only)  
Phone +1 715 623 0636  
Fax +1 715 623 2426  
sales@tsipower.com  
www.tsipower.com  
Copyright © 2010 TSi

# Outdoor XUPs



## Mounting on a concrete pad with U-channel

Following is a drawing of a recommended pedestal/concrete pad mounted installation using the TSi Power aluminum U-channel mounting brackets. When ordered with these, the units will come with them already bolted to the bottom of the cabinet. There are four pre-drilled bolt holes that will then allow bolting of the unit to a concrete pad or other mounting surface, such as a Quazite® pad or Unistrut®.

### Outdoor XUPs pad mounted

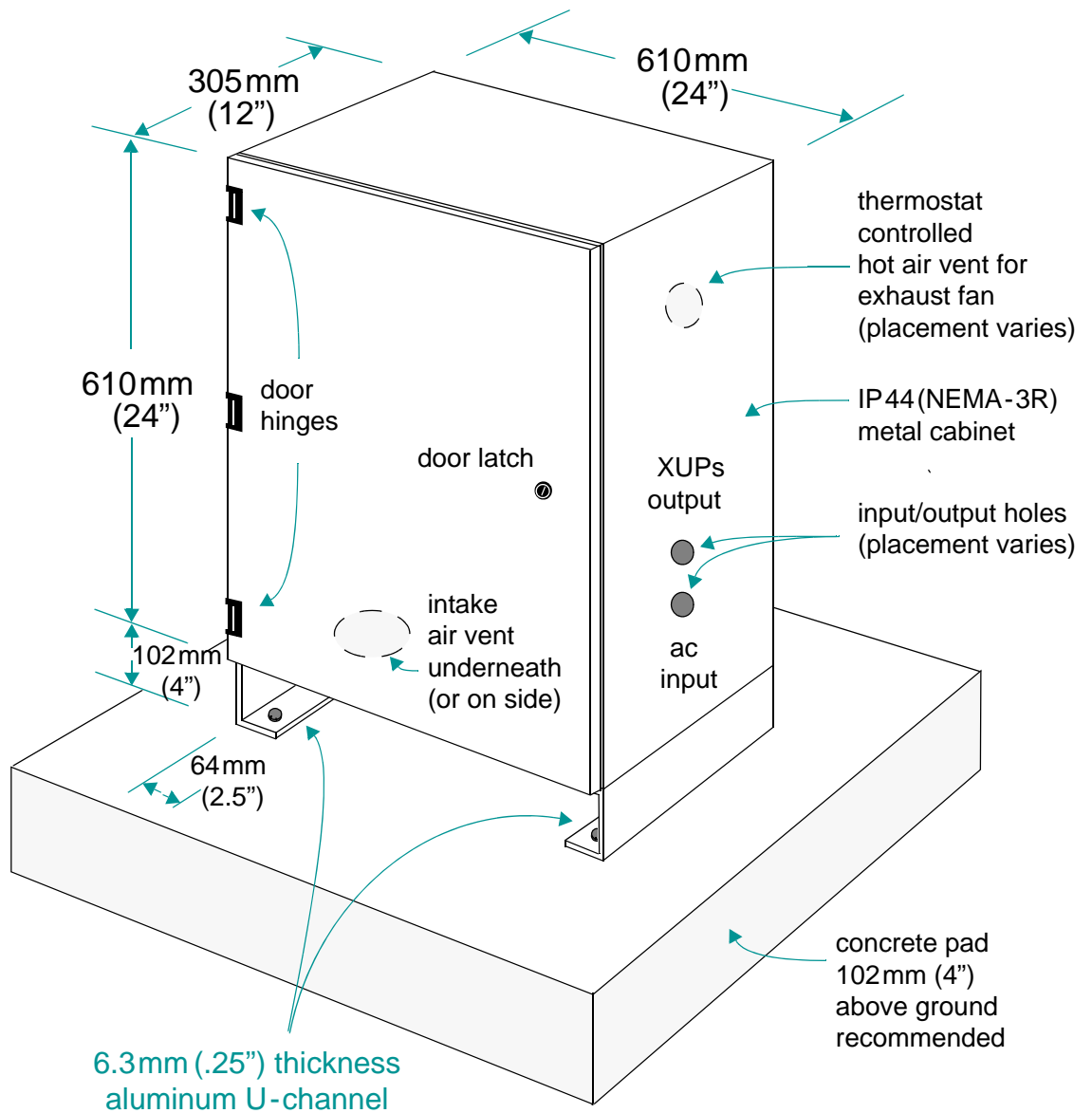

**TSi Power Corporation**  
1103 West Pierce Ave  
Antigo, WI 54409 USA  
800 874 3160 (USA only)  
Phone +1 715 623 0636  
Fax +1 715 623 2426  
sales@tsipower.com  
www.tsipower.com  
Copyright © 2010 TSi