

Authors

Peter Nystrom

President  
TSi Power Corp.

# Protection of Telecom Sites in Countries with Unstable AC Mains



*AC mains voltages frequently fluctuate beyond the IEC standard of a 184–264 V input range.*

## Background

Developing countries often have weak power generation and distribution systems. This frequently results in mains voltage fluctuations beyond the 184–264 V input range mandated by the European norm. The underlying IEC (International Electrotechnical Commission) standards assume that power generation and distribution are fairly stable and that voltage excursions will not be outside the specified input window of 184–264 V. Unfortunately, that is not the case in many developing countries throughout the world. Even industrialized nations have their share of problems with AC mains availability, where mains voltages frequently fluctuate beyond the assumed 184–264 V input range.

In the U.S. state of California, for example, a failed deregulation scheme, coupled with the lack of corrective political will, led to rolling blackouts that cut power to millions in early 2001. The desired expansion of generation and distribution capacity in developing countries is also constrained by a shortage of capital and, in some cases, political factors as well. Thus, it appears that the quality of AC mains, in both developed and developing countries, is at best uncertain into the foreseeable future.

The expansion of communications networks, such as cellular radio, direct radio access telephony (wireless in the local loop), paging networks, land mobile radio and satellite telephony stations, has led to a rapid increase of installed sites to support these networks. The proliferation of sites sometimes makes it difficult to place a particular site in an ideal location. The desired site might instead be installed in a remote or difficult-to-access location.

The author of this article has worked with infrastructure manufacturers and operators to address power-related reliability problems, which can be very expensive if not addressed properly –especially for remote and hard-to-reach locations. This paper aims to give readers some helpful hints when addressing their own power-related reliability concerns.

## The Problem

*AC induction motors are sensitive to both high and low mains voltage.*

The power converters used in modern AC–DC rectifiers, UPS and AC-DC switched-mode power supplies are typically based on the IEC input range of 184–264 V. AC induction motors are sensitive to both high and low mains voltage, where low voltage can cause rotor lockup following a dip in mains voltage and high mains voltage can lead to saturation-causing tripping of circuit breakers. Transformers and other 50/60 Hz magnetics can easily get saturated when exposed to high input voltage, particularly at 50 Hz, when the magnetization curve of steel becomes non-linear much quicker than for 60 Hz.

### *Causes of power supply failure*

- **Sags and undervoltages** can cause component overheating and destruction of MOS-FETs (metal-oxide-semiconductor field-effect transistor) from over-current.
- **Surges and overvoltages** can cause component overheating, destruction of MOS-FETs or can trigger other electronic components such as SCRs, MOVs and input capacitors which may be destroyed if they are rated too close to the line voltage.
- **Component overheating reduces the life and deteriorates the real reliability** as opposed to the estimated reliability based on steady-state conditions of the product.
- **False triggering** of other components can create nuisance alarm tripping or, worse, can cause overheating or destruction of other components.
- **Typical EMI filters are not well damped.** This has a dramatic effect on any voltage disturbances, resulting in oscillations inside the EMI filter under any transitional conditions. Severe voltage surges may result from fly-back from saturated inductors looking for a path to release energy.
- **Boost converters can be destroyed by surges** causing increased energy storage in the input filter, when the output capacitor is charged to an unsafe level, depending on capacitance value and the load levels for the DC–DC converter connected to the output of the boost converter.

### *Causes of semiconductor failure*

- **Most semiconductor devices are intolerant to surge voltages** in excess of their voltage ratings.
- **A fast surge (high dv/dt) of a few kV per microsecond** can cause a semiconductor to fail catastrophically or may degrade it so as to shorten its useful life.

- **Damage occurs when a high reverse voltage** is applied to a non-conducting PN junction.
- **The PN junction may avalanche** at a small point due to the non-uniformity of the electric field. In this case, thermal runaway can occur because of localized heat buildup and cause a melt-through which destroys the junction.

*Mains voltages varying between 160–330 V are common in countries like India and Pakistan*

Mains voltages varying between 160–330 V are common in countries like India and Pakistan, but are also found in many other areas. In such cases, installation of unprotected power systems and equipment can lead to an abnormally high failure rate and loss of revenue for both suppliers and users of telecom hardware.

*Mains voltage anomalies can be caused by the following:*

- **Fault clearing** where a short circuit occurs on the line and a protection device clears the fault, typically in around 3 cycles. The clearing of a fault results in a short dip and voltage recovers rapidly if the mains are stable. However, recovery can take much longer if the mains are weak, resulting in a protracted voltage sag.
- **Chronic instability** caused by interaction of voltage stabilizing devices. A good example would be an industrial area with an inadequate incoming power line, resulting in unstable mains as loads cycle on and off. To address this, users of power may then install a voltage stabilizer that will draw more current to provide a higher voltage for one facility, with the higher current draw causing a voltage drop for adjacent facilities. This, in turn, will draw more power when regulators attempt to correct the mains voltage. The end result can be a total loss of power when current draw exceeds the substation's capability to deliver the required current.
- **Weak generation capacity** will also result in fluctuating mains when utility customers compete for available power.
- **Rolling brownouts** can result when the power utility reduces the mains voltage by 10% or more in order to limit power consumption. This approach may work for fixed-resistance loads such as light bulbs, but will not for computer and telecom equipment utilizing switched-mode power supplies, because these compensate for low voltage by increasing current draw. The increased current is capable of generating increased internal heat that can lead to power supply failure.
- **Blackouts** can result when the electric utility cuts off power to selected areas in an attempt to protect major parts of the distribution system from interruptions.

Mitigation devices are often applied as a bandage, in the hope that things will get better quickly, to the satisfaction of both the telecom operator and the equipment provider. Unfortunately, applying mitigation devices without understanding the basics can actually aggravate the problem. This is especially true for power-factor-corrected power supplies, since these are more sensitive to mains disturbances than their simpler siblings with rectifier/capacitor inputs. It is the author's experience that power-factor-corrected rectifiers can trip internal protection devices when exposed to rapidly changing mains voltages.

Overvoltage protection (surge protection) against surge voltages, as well as from load switching and lightning, is governed by rational principles, first outlined by IEC-1312 in the early 1990s. The applicable IEC-Standard: IEC Technical Specification 61312-3 "Requirements of Surge Protective Devices (SPDs)" describes clearly how to coordinate SPDs to ensure that upstream devices (See Figure 1) progressively handle more energy than the SPD found on the front-end of a power supply, typically a metal oxide varistor. These sensible coordination principles are not always adhered to, which sometimes results in a lack of coordination between SPDs used in a system.

This can lead to the destruction of down-stream SPDs that clamp before the upstream SPDs, which in turn causes the destruction of the metal oxide varistors in the power supply itself.

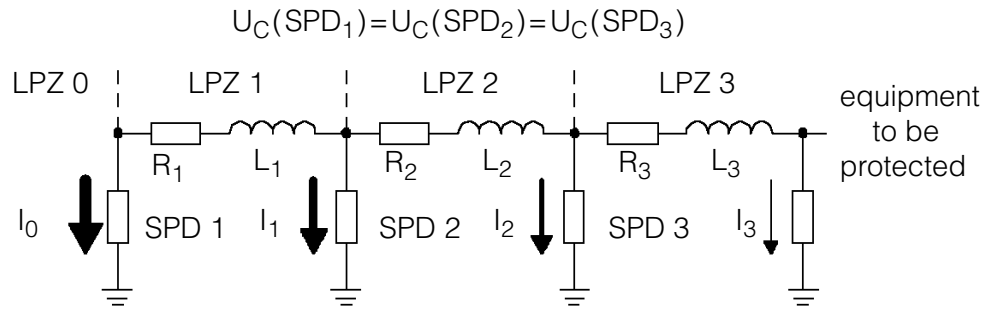

**Figure 1:** Coordination of surge protective devices.

## Safety Earthing Systems

Many different earthing systems are in use throughout the world and need to be understood before primary surge protection is implemented. The most common earthing systems are shown below:

### TN-S

A separate neutral and ground conductor are run throughout. The ground conductor can be the metallic sheath of the power distribution cable or a separate conductor. All exposed-conductive-parts of the installation are connected to ground.

### TT

One point of the source of energy is grounded and the exposed-conductive-parts of the installation are connected to independent grounded electrodes.

### TN-C

Neutral and ground conductors combine in a single conductor throughout the system. All exposed-conductive-parts are connected to the combined N-G conductor.

### IT

A system that has no direct connection between live parts and ground. All exposed-conductive-parts of the installation are connected to independent grounding electrodes.

### TN-C-S

Neutral and ground combine in a single conductor. This system is also known as multiple earthed neutral (MEN). The protective conductor is referred to as the combined neutral and ground conductor. The supply N-G conductor is grounded at a number of points throughout the network and generally as close to the consumer's service entrance as possible. All exposed-conductive-parts are connected to the combined N-G conductor.

*TN-S  
A separate  
neutral and  
ground  
conductor are  
run throughout*

## Possible Solutions

The most obvious solution is to design power supplies to withstand a much wider input voltage range to prevent saturation and resulting energy impulses that cause damage to switching transistors and other circuits. Such changes require more steel in inductors, capacitors with higher voltage ratings, possibly larger circuit boards with greater trace separation, as well as transistors with higher voltage and current ratings.

This is not likely to occur, because manufacturers would have to offer special versions with a wide input voltage range or, as a second option, make only power systems that can handle all worldwide markets, regardless of mains quality. This second option is not realistic since customers in countries with a stable mains infrastructure would be penalized.

Designing a protection device that can handle an entire power plant, or racks of power systems, is probably a more economical solution that can be used whenever increased immunity is required. Such a solution can also be used to address problems that occur in the field after installation.

## Considerations for Mitigation Devices

Mitigation devices may include a complete solution, or components thereof, if system analysis reveals that essential elements already exist. We will present here a complete solution for the readers' consideration.

### *Requirements:*

1. Input range of 160–330 V at 50/60 Hz without saturation at 50 Hz
2. Output range of 184–264 V
3. Over-voltage protection (OVP) with cut-off if output exceeds 264 V
4. Automatic bypass in case of electronics failure
5. Low impedance
6. Coordinated surge protection
7. Conversion to TN safety earthing system
8. Low weight
9. Reasonable cost
10. High power efficiency and low heat loss

*Input range of  
160–330 V  
at 50/60 Hz  
without  
saturation  
at 50 Hz*

*(An example of a power system for a cellular base station follows next page.)*

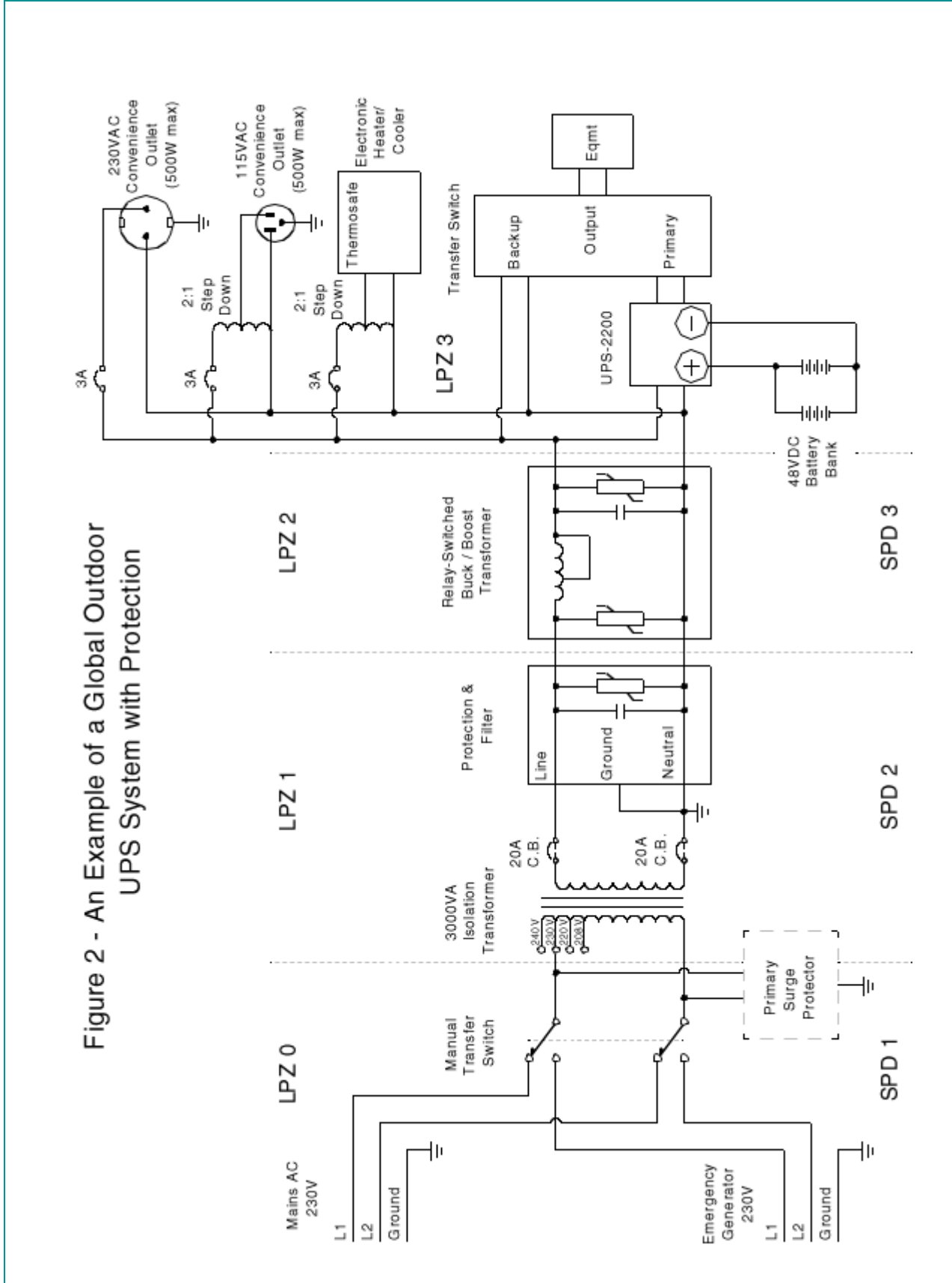

**Figure 2:** An example of a global outdoor UPS system with protection for a cellular base station.

## Limitations of Existing Technologies

Several technologies are available for mitigation devices, each with a distinct set of advantages and drawbacks. Table 1 below provides a summary:

Technology	Advantages	Drawbacks
<b>Ferroresonant transformer with isolation</b>		
	Reliability	Price
	Surge protection	Stability
	Tight regulation	High impedance
	Fast regulation	Limited input voltage range
	Bypass is not required	Frequency sensitive
		Low efficiency
		Incompatible with power factor-corrected power supplies
		High weight and bulky
<b>Tap-switched auto-transformer</b>		
	Lowest cost	Slow response
	High efficiency	Limited input voltage range
	Low impedance	Automatic bypass not available
		Requires added isolation transformer to achieve proper surge protection
<b>PWM-regulated buck-boost transformer</b>		
	Very tight regulation	Medium reliability
	Low impedance	Limited input voltage range
	Excellent stability	Most do not have overvoltage protection
	Low weight and small size	Requires added isolation transformer to achieve proper surge protection
	Very high efficiency	
	Some have automatic bypass	
<b>Relay-switched buck-boost transformer with auto-bypass and overvoltage protection (OVP)</b>		
	Very wide input voltage range of 160–330 V	Requires added isolation transformer to achieve proper surge protection
	Low impedance	
	Excellent stability	
	Low weight and small size	
	Very high efficiency	
	Automatic bypass	
<b>Variable transformer with buck-boost transformer</b>		
	Very tight regulation	Very slow
	Low impedance	High weight and bulky
	Excellent stability	Slow regulation
	Very high efficiency	Can produce excessive voltage following restart after mains failure
	Some have automatic bypass	Some do not have overvoltage protection
		Requires added isolation transformer to achieve proper surge protection

**Table 1:** Limitations of existing technologies.

## Summary

Many equipment malfunctions can be traced back to inadequate infrastructure for power generation and distribution and inadequate installation practices.

The risk of system failure is greater at 50 Hz, especially for high mains voltages.

A plethora of safety earthing systems and supply voltages make it difficult to create a simple standard for field installation.

A standardized system of mitigation devices with AC mains stabilization that also meet the requirements of IEC Technical Specification 61312-3 may be the best way to ensure consistent system performance.

## About the Author

Peter Nystrom is the president of TSi Power Corporation and has been in the power protection industry for over 30 years. He can be reached at: [peter@tsipower.com](mailto:peter@tsipower.com).

TSi Power specializes in manufacturing indoor and outdoor UPS, line conditioners, precision automatic voltage regulators, automatic transfer switches and DC-AC inverter systems designed to meet the challenging international power conditions.



**TSi POWER**

**TSi Power Corporation**

1103 W Pierce Avenue  
Antigo, WI 54409 USA

**Tel:** +1-715-623-0636

**Fax:** +1-715-623-2426

**Email:** [sales@tsipower.com](mailto:sales@tsipower.com)

**Toll free:** 1-800-874-3160

**Web:** [www.tsipower.com](http://www.tsipower.com)

Copyright © 2012 TSi Power Corp.